

## ***Insta-DE Frame Series***

### **Section 1: Screen Design**

#### **1.1 What is it?**

Instantly transform any wall or window into a white board projection screen: The soft-padded dry erase whiteboard projection screen with **VersaWhite** 1.1 gain material is the ideal solution for short throw projectors and educational training facilities in need of both a projection screen and a writing surface.

#### **1.2 How does it work?**

It is made with our award-winning and GREENGUARD certified **VersaWhite** "whiteboard-projection screen", which provides a wide viewing angle for projection applications. It combines the need of both chalkboard and drop down projection screen into one simple low cost solution.

Now our award winning **Insta-DE** includes a frame border and pen tray to further enhance and complement your installation.

### **Section 2: Product Features**

#### **2.1 Characteristics**

##### ***Screen Material***

- VersaWhite screen material surface is coated with a scratch-resistant optical nanotech resin to enhance the durability as a long term dry erase board
- Active 3D, 4K Ultra HD, and HDR Ready
- Wide diffusion 180° viewing angle with 1.1 Gain
- Available in the following diagonal size:
  - 102" in 16:9 format

##### ***Design and Installation***

- Designed for the meeting room, educational and training facilities
- Instant soft-padded dry erase screen - Stick it up, Project & Write
- Instantly convert your blank wall space into an educational combination of projection screen and dry erase board
- Unique optical coating provides high diffusion uniformity and superior color reproduction
- No "glare" effect on projection surface as typically experienced on standard white boards
- Includes markers, erasers, ABS frame border, and Pen Tray

##### ***Quality and Reliability***

- GREENGUARD® and GREENGUARD® Gold Certified (UL 2818) for safe indoor emissions
- 5-year manufacturer's warranty

## 2.2 Certifications



## 2.3 Model Numbers

Model Number	Nominal Diagonal	Aspect Ratio	Viewing Height (in)	Viewing Width (in)	Screen Material	Gain	Border Color	N.W. (lbs)	G.W. (lbs)	Packaging Dimensions (LxWxH)
IWB102HWF	102"	16:9	49.6	88.5	VersaWhite	1.1	Black	4.5	9.3	61.8"x6.1"x6.1"

## Section 3: Screen Material Specifications

### 3.1 Characteristics

**VersaWhite** Material performs as versatile as a Matte White screen material with the addition of being a dry-erase surface as well. The surface is coated with a scratch-resistant nanotech resin and transparent dry-erase layer for use as a white board while keeping uniform diffusion and enhancing true color rendition.



### Features & Benefits

- Unique optical coating supports high uniformity with picture clarity dry-erase whiteboard
- Gain: 1.1
- View Angle: 180° (90° ±LR)
- Mildew Resistant
- Active 3D, 4K Ultra HD, and HDR ready
- No "glare" on projection surface
- Surface can be cleaned as dry erase whiteboard
- GREENGUARD® and GREENGUARD® Gold Certified | UL 2818

Specifications	
Thickness	0.36 mm (0.014")
Weight	350 g/m <sup>2</sup>
Maximum Height	3.2 M (10 ft)
On-axis Gain	1.0
Half-Gain Angle	Does not reach half gain

### VersaWhite Screen Material

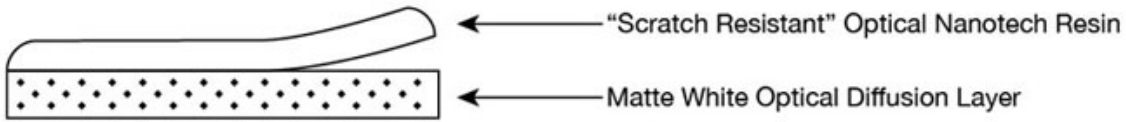

### 3.2 Gain and Viewing Angle



**On axis 0° Gain: 1.1**  
**Viewing Cone: 180°**

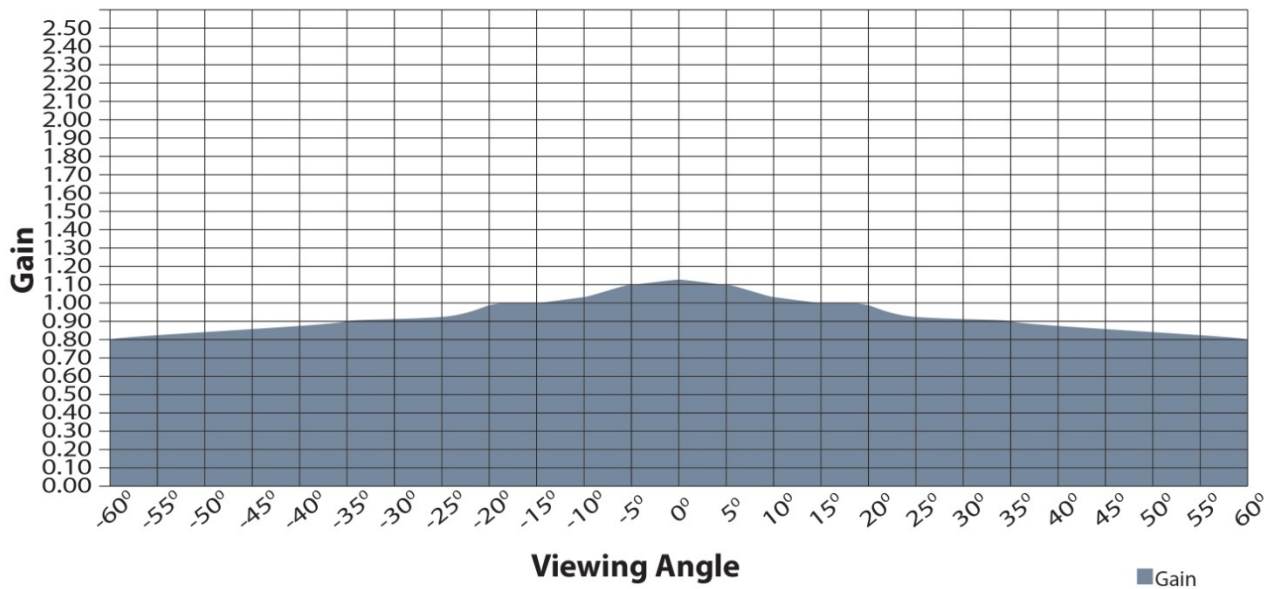

## Section 4: Execution

### 4.1 Product Features

- Award winning and GREENGUARD certified VersaWhite material.
- 1.1 gain with 180 degree wide viewing angle.
- Special anti-scratch layer to ensure long use as a dry-erase/projection screen.



### 4.2 Application Advantages

- Instantly converts flat surfaces/walls into a dry-erase whiteboard projection screen.
- Includes adhesive black velveteen border to enhance contrast and overall appearance.
- Perfect dry-erase and projection solution for today's short throw projectors.
- Ideal and effective instructional presentation tool in the classroom, boardroom, and training facilities.

**4.3 What's in the package?**

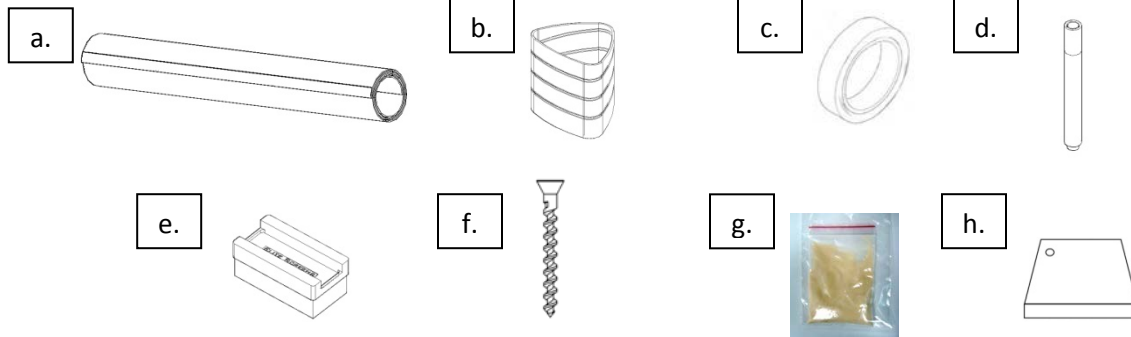

Model Number(s)	Tape Qty	Powder Qty
iWB63VW	2	1
iWB84VW/iWB95XW/	2	1
iWB4x20HW	3	2
iWB4x30HW	3	3

Parts List	QTY
a. Insta-DE Screen Material	1
b. Pen Holder	1
c. Double-sided tape rolls	See table
d. Whiteboard markers	2
e. Elite special high density eraser	2
f. 4.5mmx30mm Screw	1
g. Powder Compound	See table
h. Smoothing Tool	1

Notes:

1. For best results and maximum product longevity, ONLY use EliteProAV high density whiteboard Eraser
2. Please use a microfiber cloth and clean water to cleanse the surface every 2-4 weeks to maintain a fresh and clean projection surface.

Tools required (not included)

Carpenter's Pencil



Measuring Tape



Shop Towels



Roller cover and frame



Paint Tray



150 grit sandpaper



Dust Mask



Safety Goggles



R-35 Primer



**4.4 Pre-Installation Notice**

The Insta-DE product is to be solely installed on flat surfaces. Prepare the flat wall/surface by cleaning the entire area. Do not install if any imperfections are found on the surface such as drilled holes, glue/tape residue, dents, etc. We recommend sanding the area first to make sure you have a clean flat and smooth surface. Failure to remove such imperfections can damage the product. The dry erase function of this product requires a smooth writeable surface and EliteProAV is not responsible should these instructions are not be properly followed.

**Take the Insta-DE Screen out of the package, unroll it on a clean surface and lay it on its front side.**

**Before applying the Insta-DE, the application surface must be dry, clean, smooth, and structurally sound.**

1. Clean the surface to remove any dirt, grease, and wax.
2. Fill any depressions or holes with a drywall compound
3. Use sandpaper to smooth any bumps and blemishes. Sand until the surface is completely flat.
4. Level-5 finish to the surface and apply one coat of Professional R-35 primer

**The warranty of this product will be voided if any bubbling occurs due to the use of an after-market spray adhesive or if the screen was applied on to a textured wall**

#### 4.5 Installation

**Double Sided Tape Installation- Only use this method for models iWB63VW/iWB84VW/iWB95XW. For sizes larger sizes, refer to the glue powder compound method detailed on page 4.**

1. Clean the location where the **Insta-DE Screen** will be installed.
2. Measure and mark the top-right and bottom-right corner of the installation location

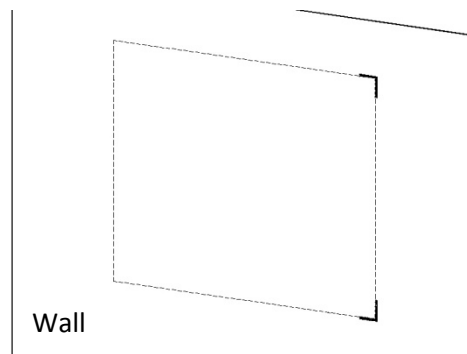

3. Apply double-sided film tape all around the edges of the Insta-DE back padding.

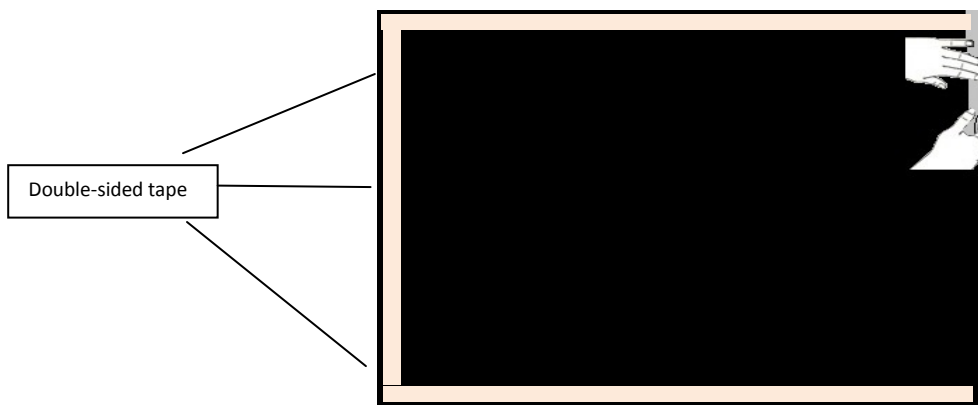

4. Completely peel the entire left side (back) vertical tape strip and peel off a 1-inch length tape film on the rest of the tape strips.

5. Attach the Insta-DE Screen to the top-right and bottom-right corner of the installation location.

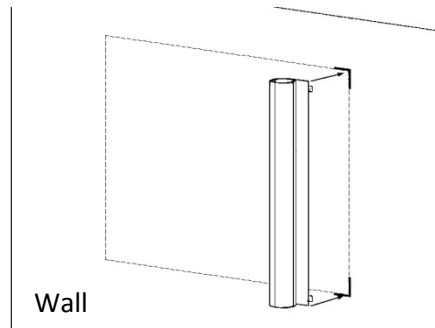

6. Remove the tape film on the horizontal sides while unrolling the material and firmly attach to the taping line with pressure.
7. Continue attaching the double-sided adhesive tape until you've reached the end.
8. Lastly, remove the entire vertical tape strip at the end, line up with the tape line to complete the installation.

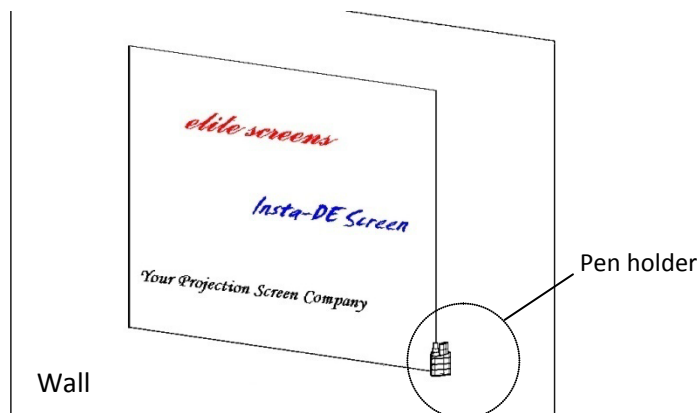

#### 4.6 Glue Powder Compound Method for models iWB102HW/iWB4x10HW/iWB4x20HW/iWB4x30HW

We strongly recommend two or more people for this installation.

1. Smoothen the entire surface of the wall with sandpaper.
2. Clean the entire surface with a wet sponge or lint-free towel to remove any dust left from sanding the wall.
3. Measure and outline the screen installation area.

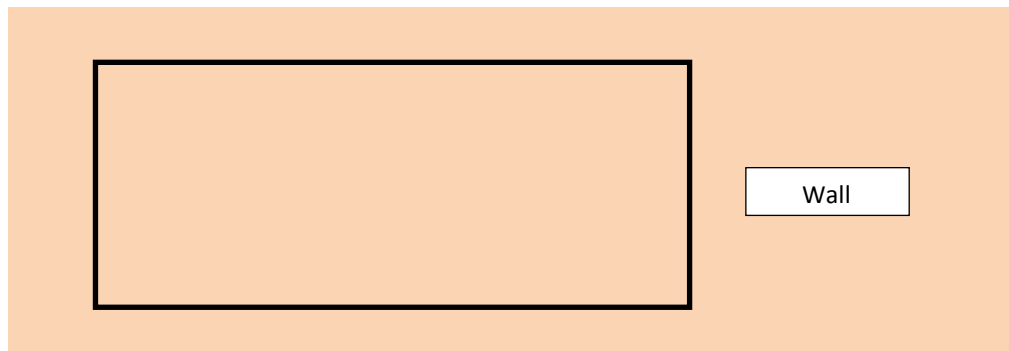

4. Apply the included double-sided tape over the line. Do not remove the top film of the tape.
5. Pour an entire powder bag into a paint bucket filled with 25 oz. of room temperature water and stir until all lumps are gone and the compound has a syrup texture. This will make the mixture into an adhesive compound for sticking the film to the wall.  
  
Note: Once the compound has been mixed, it must be applied within 4 hours to ensure a sealed installation of the Insta-DE to the wall. Use one bag for every 25 oz. of water.
6. Pour the mixture into a paint tray and dip the roller.
7. Evenly apply a thin coat of adhesive to the surface evenly with a paint roller.
8. Wait for the adhesive to dry.
9. Sand the surface until no adhesive residue remains.
10. Apply one coat of Professional R-35 Primer (do not allow it to dry) and immediately apply the Insta-DE to the wall.
11. Unroll the Insta-DE on to the wall lining it up with the drawn line from Step 1.

**Note : Do not allow the material to wrinkle or crease to avoid permanent damage.**

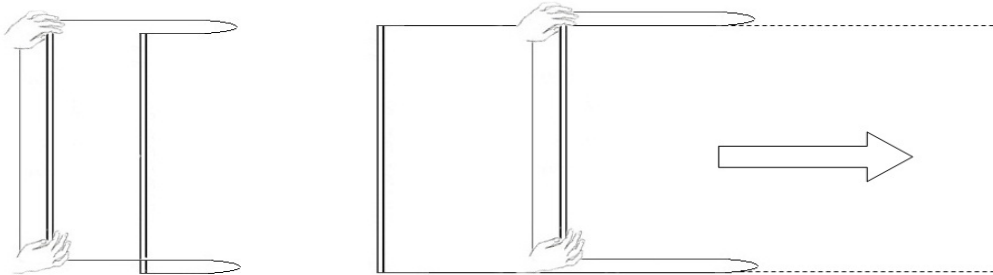

12. Flatten the surface with a flexible wall smoothing tool in a 45 degree angle to avoid scratching the surface.

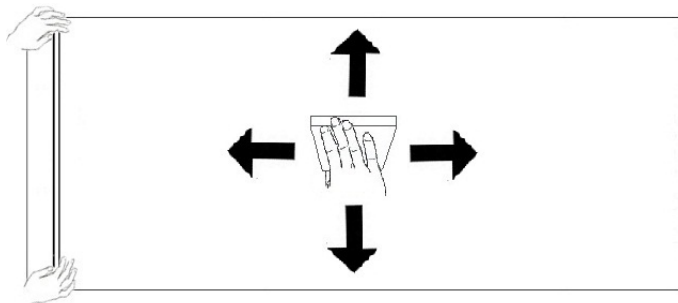

**Caution: The smoothing tool's edge is sharp. Carefully scrape the screen when removing air bubbles to avoid scratching the surface.**

13. Lift edges and smoothen out any remaining air bubbles.

14. Peel off the top layer of the double-sided tape and flatten the screen’s edges with the smoothing tool.
15. Use a soft damp towel or sponge to clean entire surface.

**4.7 Pen holder Installation**

**Method one:** Peel the tape strip off the back of the pen holder and attach the pen holder to the wall or your preferred location.

**Method two:** Install the included screw in the wall and hang the pen-holder. See diagram below for details.

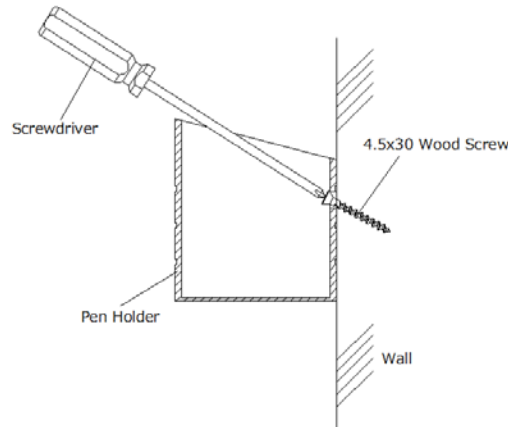

**Caution:**

*The double-sided tape is meant to be permanent for the life of the product. It does not remove easily. Please attach very carefully to avoid having to remove the product and positioning it in a different location.*

Use only the included erasers to remove and erase dry-erase markings. For a deep clean, we recommend using a non-alcohol based dry-erase board cleaner with a soft microfiber cloth.

Elite offers a replacement kit (**part number ZER3**) which includes:

- 1 x bottle of 8.45 oz cleaning solution
- 1 x microfiber cloth
- 2 x high density foam erasers
- 2 x sets of dry-erase markers (4 total)



Contact your reseller or visit [shop.elitescreens.com](http://shop.elitescreens.com) for pricing and purchase.

**4.8 Safety Precautions**

- A. Avoid using sharp objects directly on the screen which can result in permanently damaging the product and voiding your warranty.
- B. Creases or wrinkles caused by improper installation are not removable.

**Attention:** Prior to installation, please view the following on-line video found at this link for your reference → [www.elitescreens.com/ide2install](http://www.elitescreens.com/ide2install) (Same method for Insta-DE)



**Below are sample pictures of improper installations.**



**Section 5: Product Specifications**

**5.1 Dimensions**

Model Number	Diag. Size	Aspect Ratio	Screen Height	Screen Width	View Height (A)	View Width (B)	Frame Height (A1)	Frame Width (B1)	Tray Width (B2)	D	D1
Unit: Inches											
IWB102HWF	102"	16:9	50.0	88.9	49.6	88.5	51.1	88.5	50.8	0.1	1.8
Unit: mm											
IWB102HWF	102"	16:9	1270	2257	1260	2247	1298	2247	1290	4	45

**5.2 Drawings**

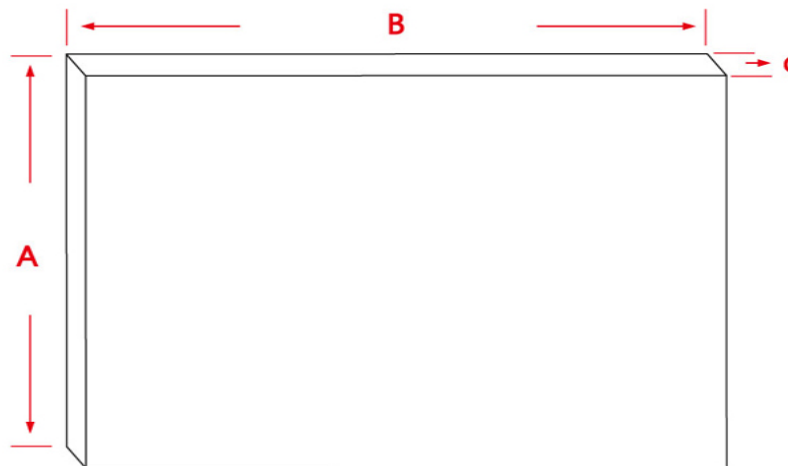

### 5.3 Pictures

#### *Insta-DE Frame Series*



#### *Insta-DE Frame Series* Material

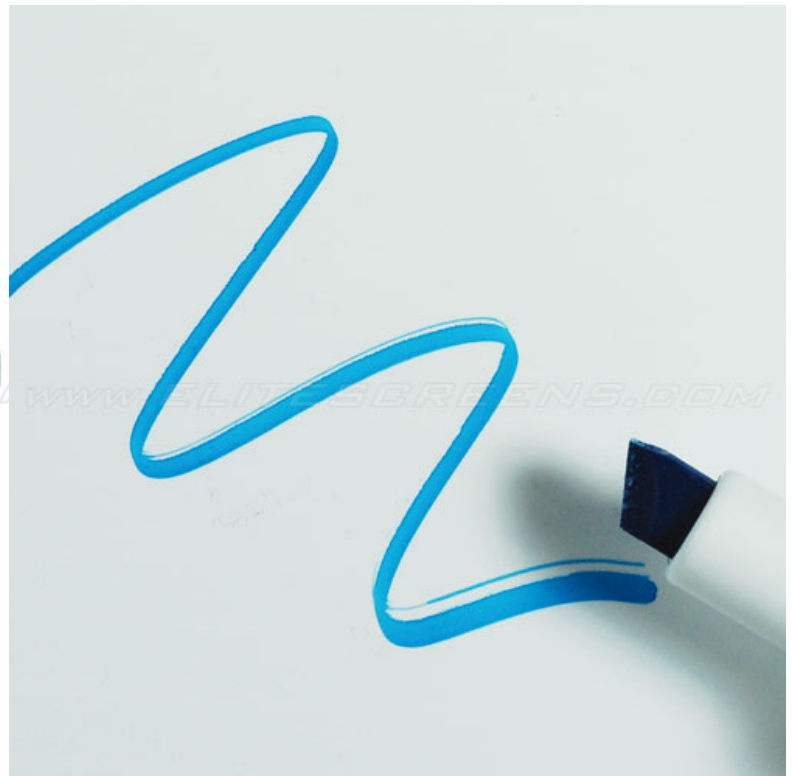

Self-Stick Accessory Cradle Detail



Pen Tray Detail

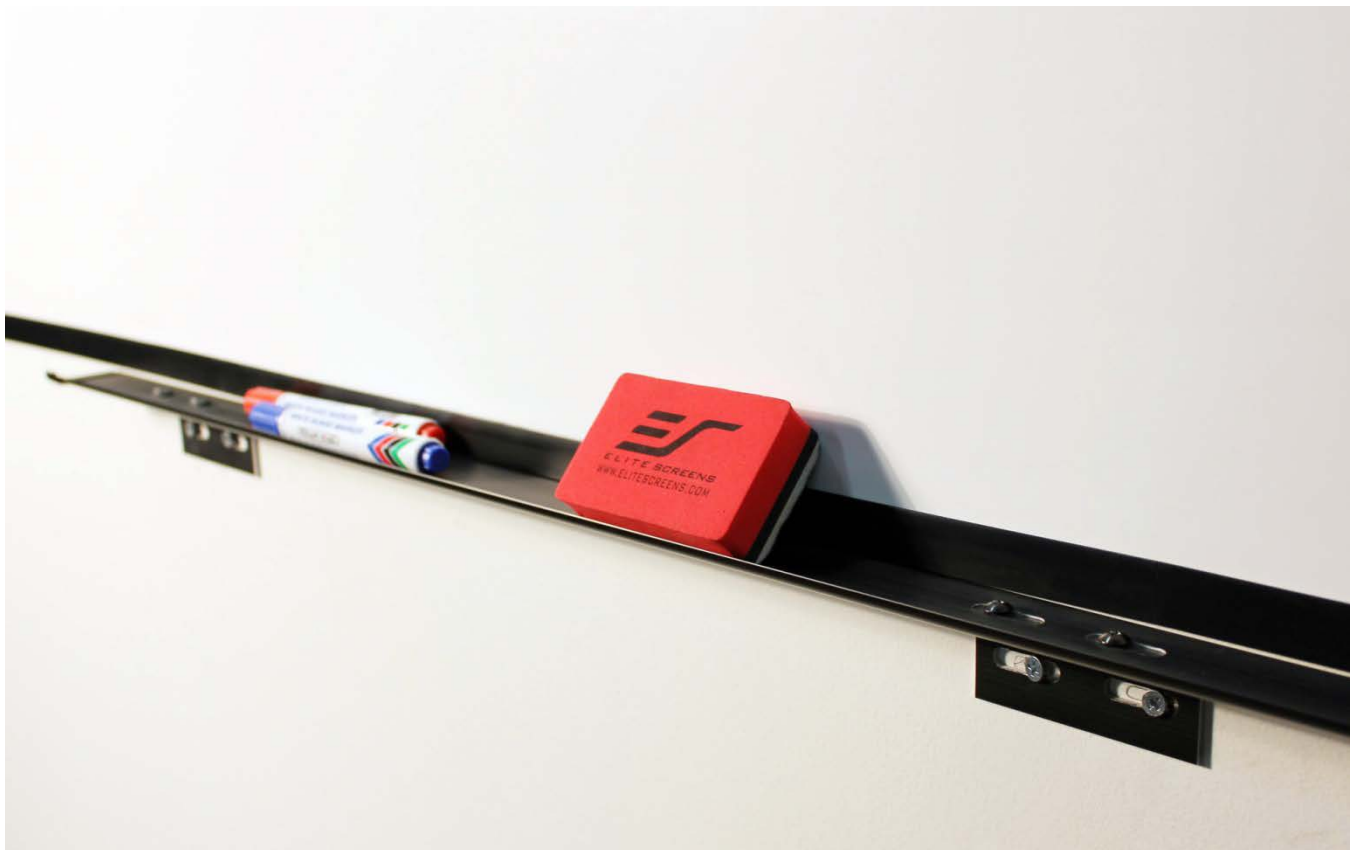

Application

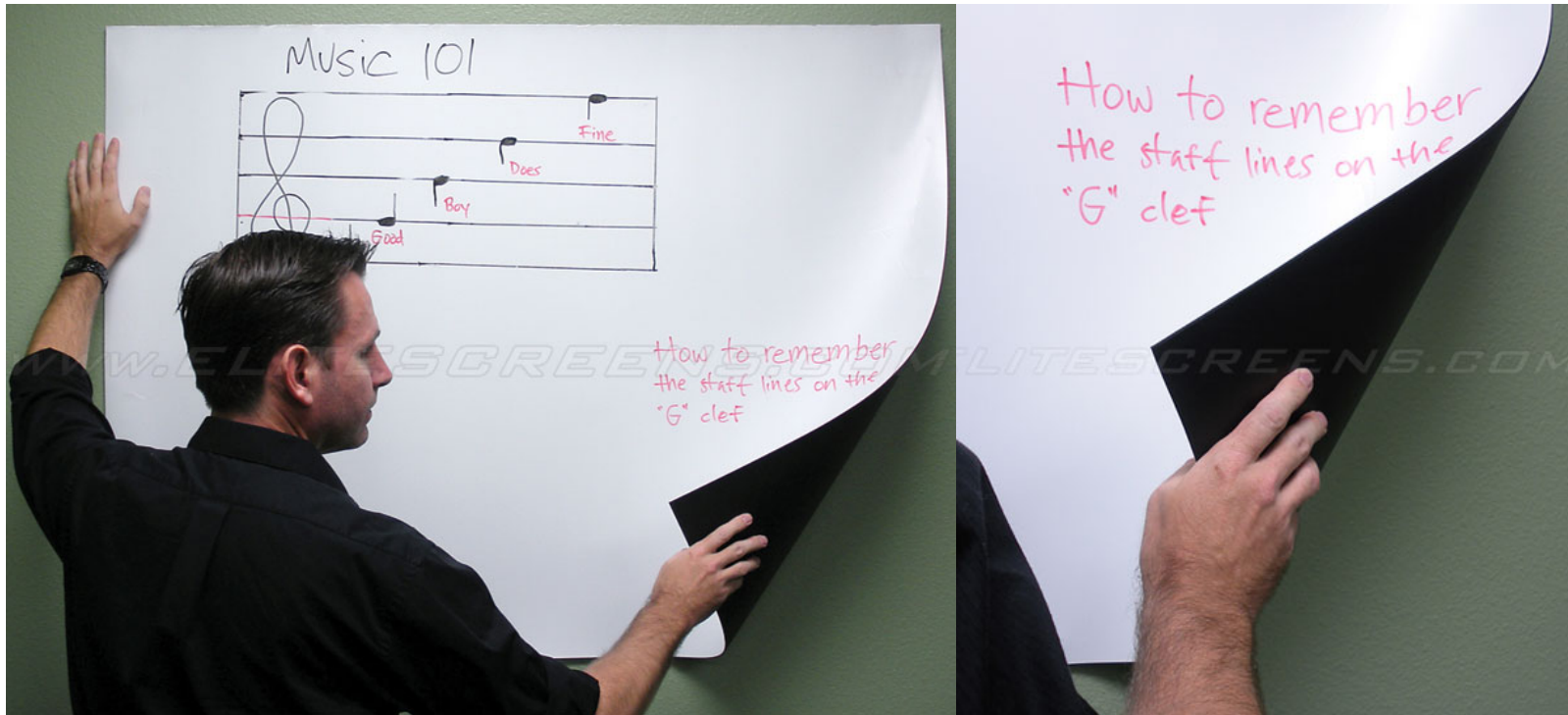

Life Style





**Section 6: Company Description**

**6.1 About EliteProAV™**

EliteProAV™ is a manufacturer of projector screens for the commercial AV sales channel. It is a division of Elite Screens Inc., an ISO9001:2015 certified manufacturer that is presently the leading international brand of CE Retail projector screens with offices located worldwide.

EliteProAV™ provides an array of dedicated commercial grade projector screens for professional integrators. This includes certified products that are also compatible with building codes as well as programs, warranties and trained professionals to assist installers every step of the way. Product is available through a series of regional warehouses located in Southern California, Texas, Georgia, and Maryland. EliteProAV™ is located at 12282 Knott St. Garden Grove, CA 92841. For more information, please call 877-511-1211 or visit <http://www.eliteproav.com>.

###