



Tension Pro Series – E type

Large Electric Tab-Tensioned Projector Screen
(For models above 300” and bigger)
User’s Guide – RC1 V1.0

Important Safety & Warning Precautions

Make sure to read this user’s guide and follow the procedures below.

Caution: The screen’s Black Top Drop is already set to its maximum drop distance. **There is NO extra Black Top Drop in the roller.** Please be aware of this as it will void your warranty with Elite ProAV. Unapproved changes or modifications (except for cutting the power cord for hardwire installations) to this unit are prohibited and will void your warranty.

Elite ProAV allows a 1.5% tolerance within the viewing surface for expansion and contraction of the screen materials over time.

- Please retain this user’s guide for future reference.
- To avoid damaging the unit, do not use with any unauthorized accessories not recommended by the manufacturer.
- Handle the unit carefully during transportation to avoid any damages.
- To ensure safe and reliable operation, direct connection to a properly grounded power source is advised.
- The power outlet supplying power to the unit should be close to the unit and easily accessible.
- Do not install the unit on uneven or inclined surfaces.
- Do not put heavy objects on the power cord and position it properly to avoid creating a trip obstacle.
- Never overload the power cord to prevent an electric shock or fire due to a loose contact or a short circuit.
- There are not user serviceable parts in this unit. Do not attempt to disassemble this unit by yourself. No one except authorized technicians can open and make repairs to this unit.
- Make sure the power source of this unit is connected and has a continuous power flow.
- If there is need to use an extension cord, make sure the cord has an equal rating as the appliance to avoid overheating.
- Do not handle the power plug when your hands are wet, or your feet are in contact with water.

Do not use this unit under the following circumstances.

- Disconnect the power cord under the conditions of heavy rain, wind, thunder or lightning.
- Avoid direct Sunshine, rain shower and moisture.
- Keep away from fire sources and high temperature to prevent this device from overheating.
- Cut off the power supply first before transportation or maintenance.

- Fully disconnect from the power supply when the unit is not in use for a long period of time, as should be done with any other electric household appliance.
- To avoid possible injury and/or an electric shock, do not attempt to use the screen if there is obvious damage or if there are any evident broken parts.

WARNING

The Screen’s **Top Black Drop** is already set to its maximum drop distance. There is **NO** extra top black drop in the roller. Please be aware of this as it will void the limitation of your warranty.

Individual modifications to this product are prohibited and will void the warranty with the manufacturer. Please contact Elite ProAV® Customer Service for any questions.

NOTE:

This equipment has been tested and found to comply with the limits for a Class B digital device, pursuant to Part 15 of the FCC Rules.

These limits are designed to provide reasonable protection against harmful interference in a residential installation. This equipment generates and can radiate radio frequency energy and, if not installed and used in accordance with the instructions, may cause harmful interference to radio communications.

However, there is no guarantee that the interference will not occur on a particular installation. If this equipment causes harmful interference to radio or television reception, which can be determined by turning the equipment off and on, the user is encouraged to try to correct the interference by one or more of the following measures.



- ✓ **Reorient or relocate the receiving antenna of the device which may be causing the interference.**
- ✓ **Increase the separation between the screen and the device’s receiver.**
- ✓ **Connect the equipment into a different power outlet other than the device.**

Pre-Installation

1. Carefully unpack the screen.
2. Always handle the screen in a leveled position on a clean surface.
3. To protect the screen from exposure to stains, keep the screen out of contact with foreign particles such as dust, sawdust, and/or liquids.

NOTE

Regardless of the mounting method, the screen should be securely supported so that the vibration or pulling on the viewing surface will not cause the casing to become loose or fall.

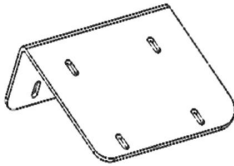
Hardware Parts List		
Please make sure all parts listed below are included before proceeding with the installation.		
A. M10 Suspended Turnbuckle Hook x 4 pcs	B. M10 eyebolt x 4 pcs (attached to bracket)	C. Bracket x 2 pcs (Installed on each side of the screen)
		

Installation Instructions

For installation assistance, please consult a professional Installer. Elite ProAV is not liable for faulty installations.

CAUTION: Product is very heavy. Installer must ensure that structure is of adequate strength to properly and safely sustain the screen.

Please note: Before fully operating the screen. Remove the four shipping brackets from the weight bar by loosening the screws.

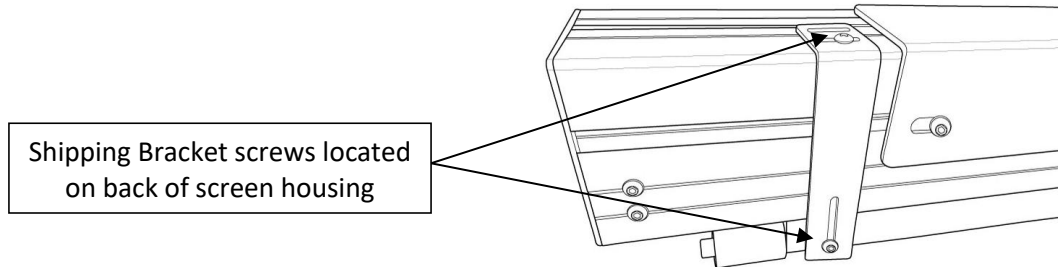

Bracket Position

Loosen the **M10 eyebolt (A)** by turning counterclockwise. Then loosen the hex screws on the back of the brackets using a 7/32 hex key to allow the bracket to slide into position as required for installation.

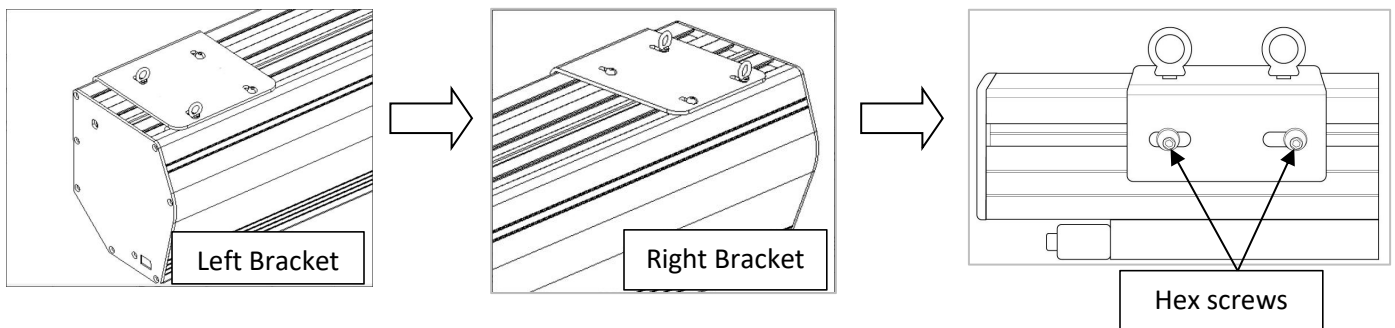

Recessed Installation

1. Select the installation location for your screen. Measure the distances between each eye bolt (Shown as measurements **L** and **A** in Fig.1). Mark the installation area on the ceiling based on the measurements taken. Using the marks as a guideline, drill a hole in the ceiling for each **suspension bolt hook** (not included).

2 **Note:** The distance between the installation hole (**M**) and the wall should not be longer than measurement **A**.

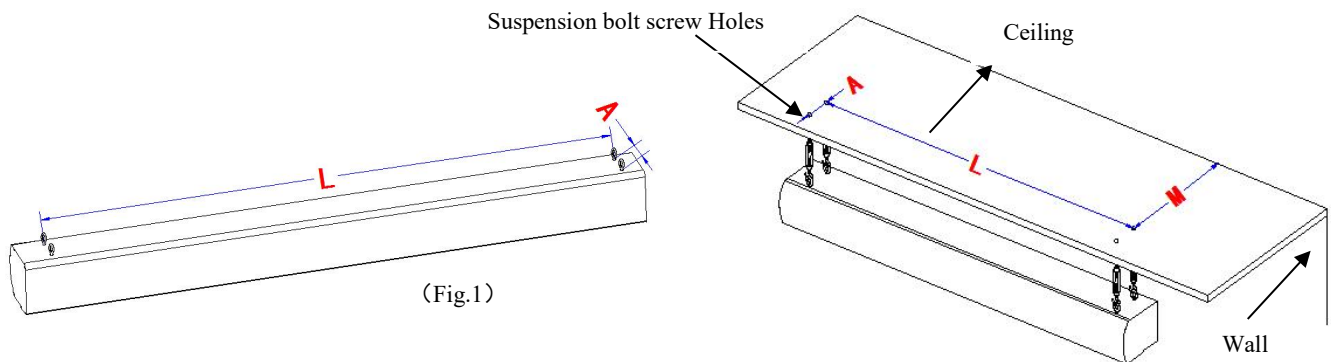



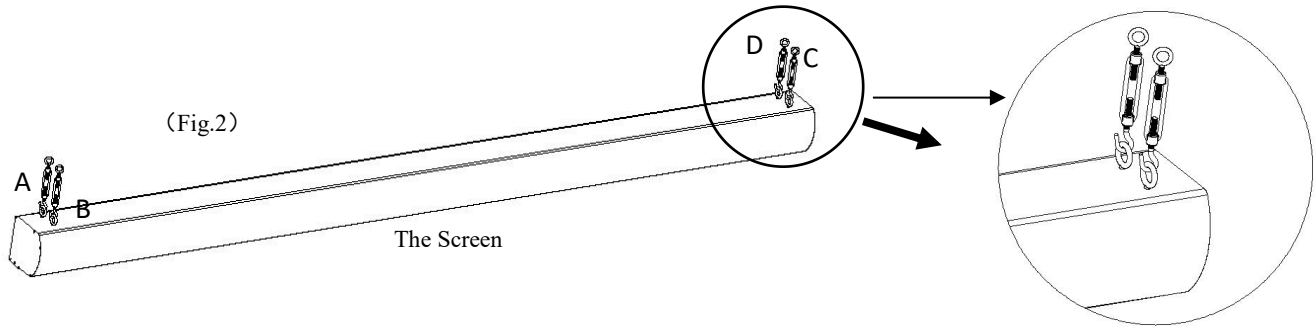

3. Next, attach the **M10 Suspended turnbuckle hooks (A)** to all four **M10 eyebolts (B)** installed on the brackets (A/B/C/D). Then hang the screen to the **suspension bolt hooks** installed on your ceiling.

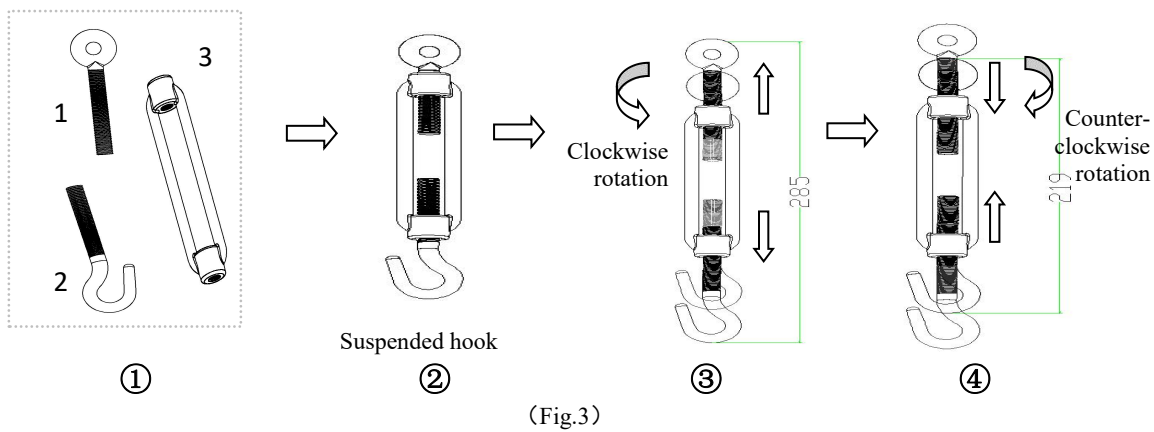

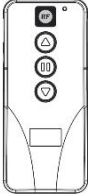
After the installation is complete, if the screen is not leveled, you can adjust the height of the suspended hooks to level the screen. Below are the adjustment methods for the suspended hooks. The maximum and minimum adjustable lengths are shown in Fig 3, illustration 3 and 4.

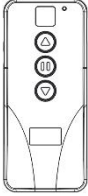
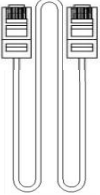

Tension Pro Series Controls and Accessories				
A. IR (InfraRed) Remote Control ZRC1-IR	B. RF (Radio Frequency) Remote control ZRC1-RF	C. Wall box controller ZRC1-WB	D. RJ50 Cable ZRC1-RJ50	E. Circuit board power box
				

Screen operation

Electric Current: Depending upon region, your Elite ProAV Screen will operate on 110v, or 220v voltage.

1. After ensuring the power outlet & screen are compatible (voltage), plug the power cord into the power outlet.
2. Once the screen's has power, you'll be able to control it using any of the 5 methods described below.
3. Remote controller requires AAA batteries (not included).

Power attachment to screen: Connect the circuit board power box cable to the screen's cable end and secure it by turning the locking sleeve clockwise.

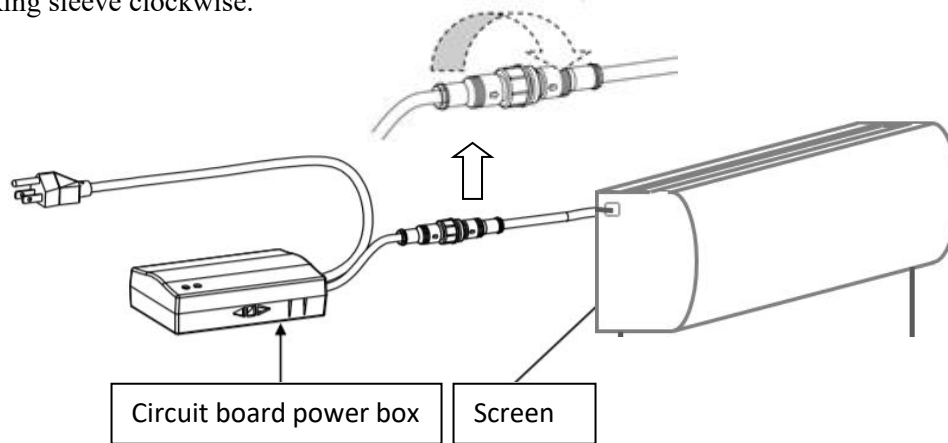

5 ways to control your Tension Pro Screen

1. IR Remote control (Item A, Fig 1): The Infrared functions by direct line of sight contact using an effective beam range of 25 feet within a 30-degree angle. Aim the IR remote directly at either the IR receiver on the Wall Box Controller or on the screen to operate the screen.

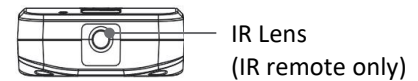

Note: Assure there is no obstruction between the IR remote and IR receiver.

2. RF Remote Control (Item B): The radio waves eliminate the need for a direct line of sight and has a longer distance control range.

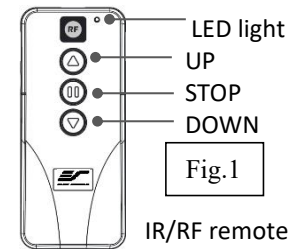

The RF remote is already pre-synced/paired and ready to use. If synchronization/pairing is needed, please follow the steps below.

How to synchronize/pair a new RF remote:

- Press & hold the “**Programming Key**”, then press the “**Up Key**” on the **Wall box controller** (wall-box LED flashes). *Reference the wall box controller section for programming key location.*
- Then press the “**Up Key**” on the **RF remote**.
- The **Wall box** LED will flash 5 times, to indicate the RF remote has been properly synchronized/paired.

How to change the RF code (For use when multiple screens/RF remotes are owned)

Changing the RF code avoids controlling multiple screens at the same time and prevents electrical interference leading to accidental control of the screen.

1. Remove the batteries
2. Change the RF code switch
3. Insert the batteries
4. Synchronize it with the wall box controller

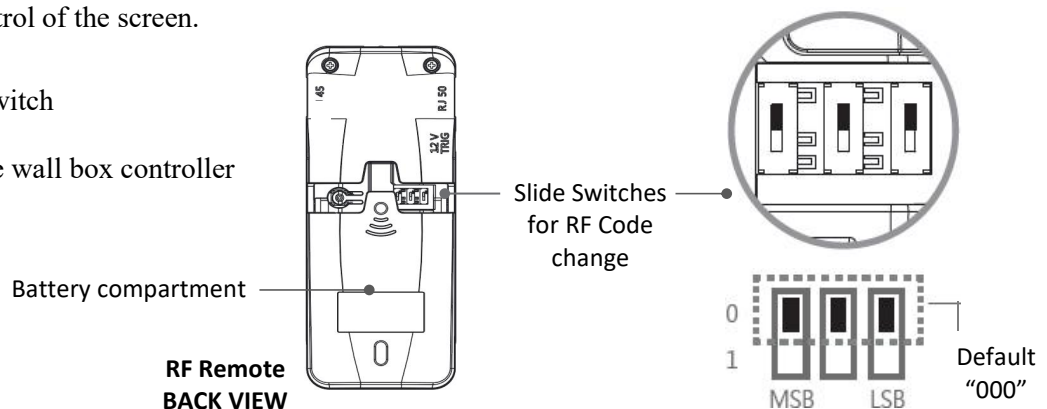

3. Wall box controller (Item C, Fig 2): The wall box controller switch is a wall mounted control box with an up/stop/down button. It plugs directly into the circuit board box's RJ50 port.

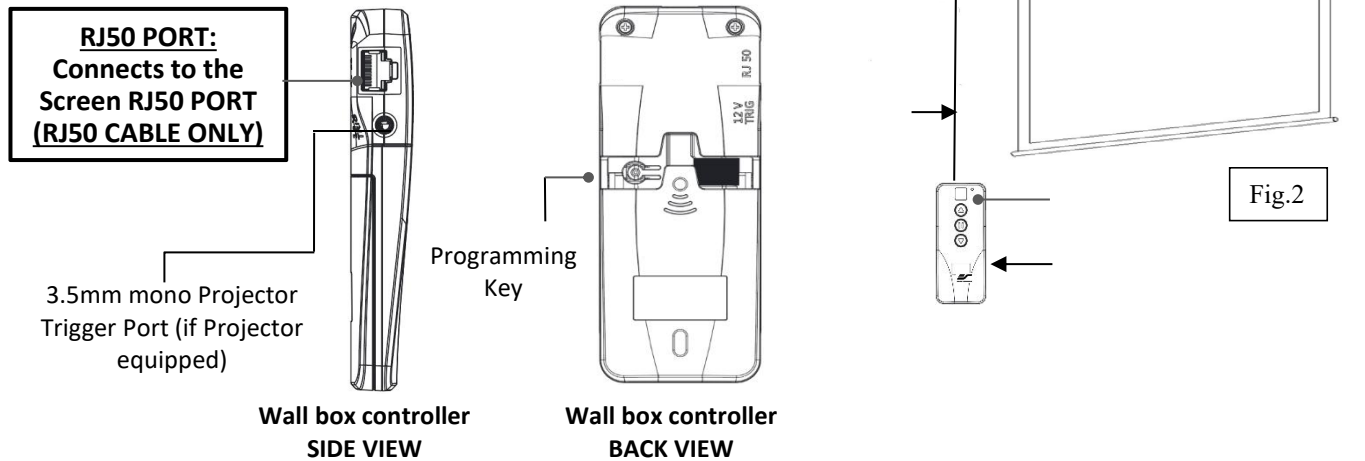

4. Wired 5-12 volt trigger (Fig 3): Requires a 3.5mm to 3.5mm mono cable (not included)

Step 1: Connect one end of the RJ50 cable to the circuit board box and the other end to the Wall box controller.

Step 2: Then connect one end the 3.5mm mono cable to the wall box controller and the other to the projector.

Once the two cables have been connected, the wired trigger feature is ready to synchronize the screen's up/down operation with the projector's power cycle.

- Projector on, screen drops
- Projector off, screen raises

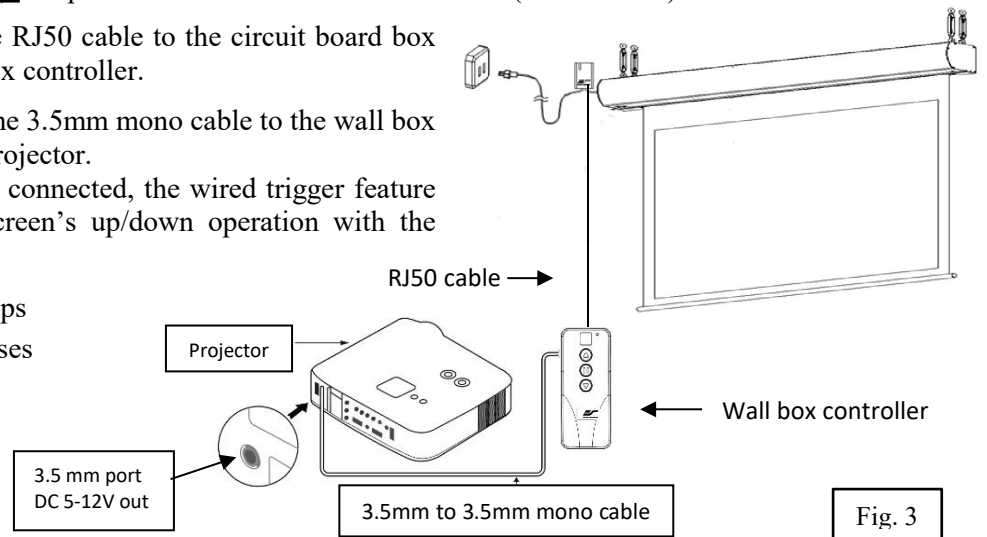

5. Wireless 5-12 volt trigger (Fig 4): Requires a 3.5mm to 3.5mm mono cable (not included).

The Radio Frequency (RF) remote control serves as a dual purpose, independently as a handheld remote control, or as a Wireless 5-12 volt trigger. The radio frequency technology sends a wireless signal that synchronizes the screen's drop & rise with the projector's power cycle.

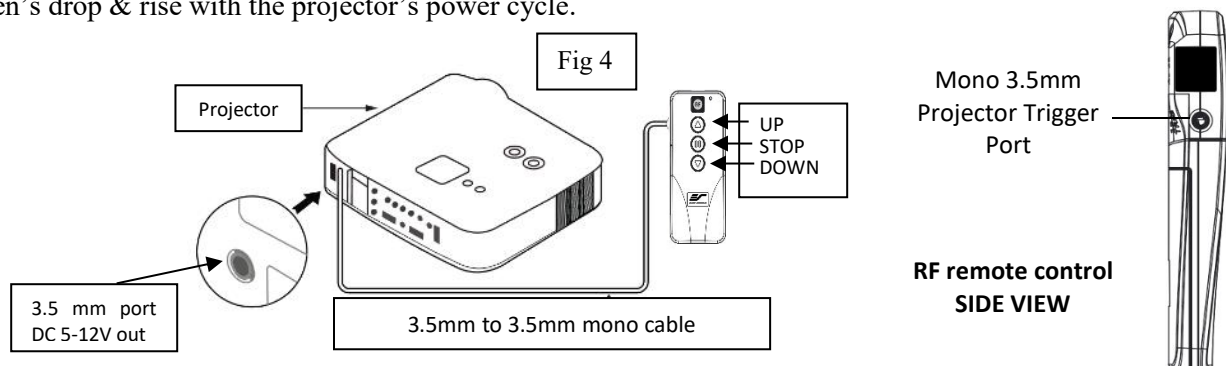

Here's how to set up your Wireless 5-12 volt trigger

The 5-12V wireless trigger should already be synced and ready to work.

Step 1: Connect one end of the 3.5 mm mono trigger cable to the RF remote.



Step 2: Connect the other 3.5 mm mono end of the cable to your projector



Step 3: Turn on the projector and the screen should automatically deploy.

Step 4: Turn off your projector and the screen should automatically retract.

(Please be aware, the projector on/off cycle may take longer to fully activate. It usually takes around 20- 30 seconds for full off and on cycle each time)

Note: If the wireless trigger feature does not work, please resync the RF remote to the Wall box controller per the instructions in the Radio Frequency remote section.

ADVANCED Programming Key Instructions: (FOR ADVANCED USERS ONLY)

* Wall box controller must be connected to the screen.

ATTENTION: Reducing the factory's full screen drop may produce waves/wrinkles on the projection surface on tab-tension screens. The full drop is recommended to allow the screen to rely on the tab-tension system to maintain the projection surface flat and taut on all sides.

The same applies on non-tensioned screens, although some level of waves may be present due to the nature of the screen not being tensioned. If wrinkles/waves develop after making the adjustment to the desired drop position, reset it to the factory's default position per the instructions below.

FLATNESS AFFECTED BY NEW PROGRAMMED VERTICAL POSITION IS NOT COVERED UNDER A REPLACEMENT WARRANTY.

1. Preset the Screen's Drop Position:

Use the RF/IR remote or Wall Box Controller to Drop the screen to the desired position you want to set it at. Press & hold the "**Programming Key**", then press the "**Down key**" on the Wall Box Controller. The LED will flash 5 times to confirm new programmed drop position.

PROGRAMMING NOTE:

The programmed vertical position relies on a time-count which adjusts itself according to the programmed timed difference. Multiple up/down programming will result in the vertical position being off a few inches. It is recommended that programming is done the **first-time** the desired vertical position is determined or RESET it to factory default and programming the desired vertical position afterwards.

2. Clear/Reset the Screen's Drop Position to factory default:

Press & hold the "**Programming Key** + "**Stop key**" on the wall box controller.

For more information, technical support or your local Elite ProAV® contact, please visit www.eliteproav.com