



Pro Frame Velvet Series

Fixed Frame Projection Screen

User's Guide

Thank you for choosing an Elite ProAV fixed frame projection screen! Please read through this user guide before utilizing the screen. Correct usage and maintenance will ensure a long product life.

Care & Use Instructions

Dust, dirt and scratches on the projection surface will affect the picture quality, please take note of the points below to prevent that from occurring:

1. Do not touch the projection surface with your hands.
2. Do not write or draw on the projection surface.
3. Do not use fingers or sharp objects to point on the projection surface; this will damage the screen material.
4. Use a soft-damp cloth to clean the projection surface; do not use chemical cleaning agents or alcohol.
5. Use clean water when dampening the cleaning cloth and do not rub against the material to clean it.

ATTENTION:

The installer must ensure that the fasteners used are of adequate strength and suitable for the installation location. Included mounting screws are complimentary and may not be appropriate for all mounting surfaces. Use appropriate anchors to safely secure the screen to the mounting surface or consult with a professional installer.

Hardware and Parts List	
A. Frame Parts	x 6 pcs (4 top/bottom frame pcs + 2 side frame pcs)
B. Screen Material	x 1 pc
C. Center joints	x 2 pcs
D. Elbow Joints	x4pcs
E. Wall brackets	x4pcs (depending on model/size)
F. Wood Screws	x 8pcs
G. Drywall anchors	x 8pcs
H. M5x15 screws	x 16 pcs
I. Center Support Bar	x 1 - 2 pcs (depending on model/size)
J. Support joiner	x 2 - 4 pcs (depending on model/size)
K. Fix Plates	x 60 - 180 pcs (depending on model/size)

Note: Please make sure all parts are included in your package before proceeding to assemble your fixed frame projection screen.

FRAME ASSEMBLY

1. Insert the *center joint (c)* connector to the $\frac{1}{2}$ horizontal frame piece and fasten it with two *M5x15 screws (h)*.

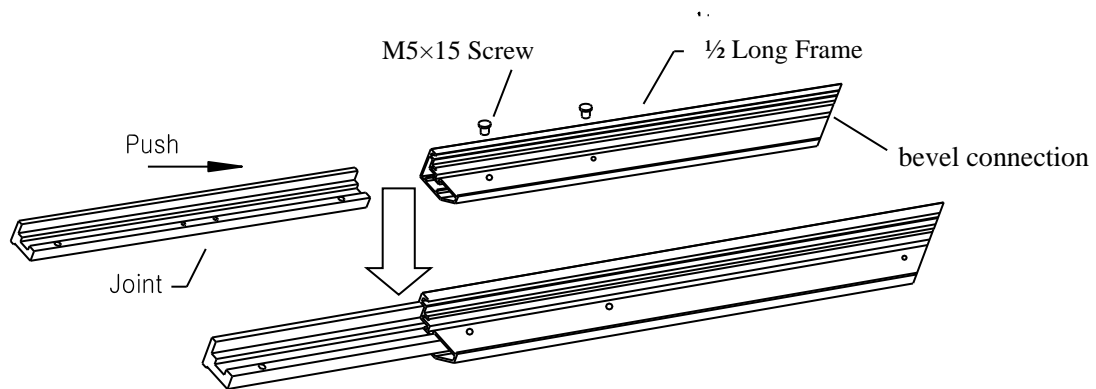

2. Insert the other $\frac{1}{2}$ horizontal frame piece to the *center joint (c)* connector and fasten it with two *M5x15 screws (h)*. Repeat steps 1 and 2 for assembling the second horizontal frame.

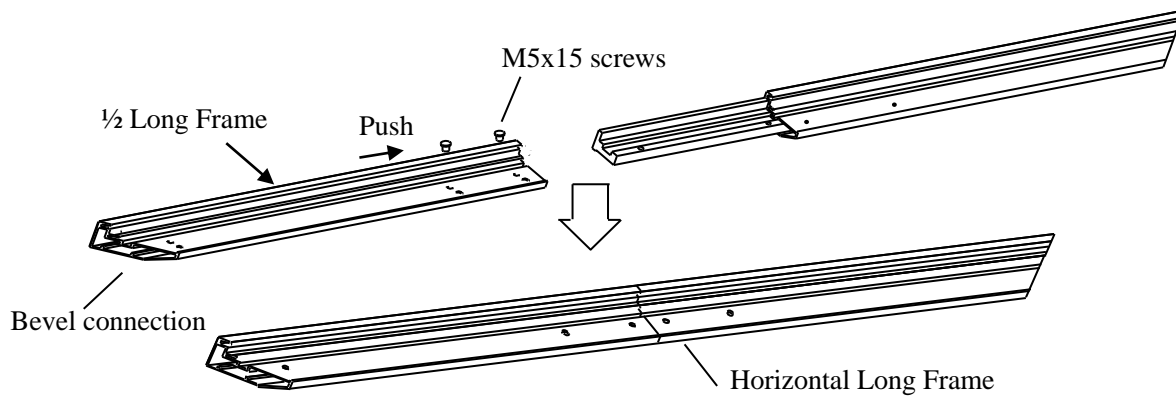

Note: a. Two $\frac{1}{2}$ size horizontal frames should be assembled for a screen.

b. Do not tighten the screws completely until all frame pieces have been assembled correctly.

3. Insert both *elbow joint (d)* connectors into the long horizontal frame and fasten it with two *M5x15 screws (h)* see **Fig.1**. Then insert the vertical short frames into the exposed *elbow joint (d)* connectors and fasten them with *M5x15 screws (fig.1.2)*.

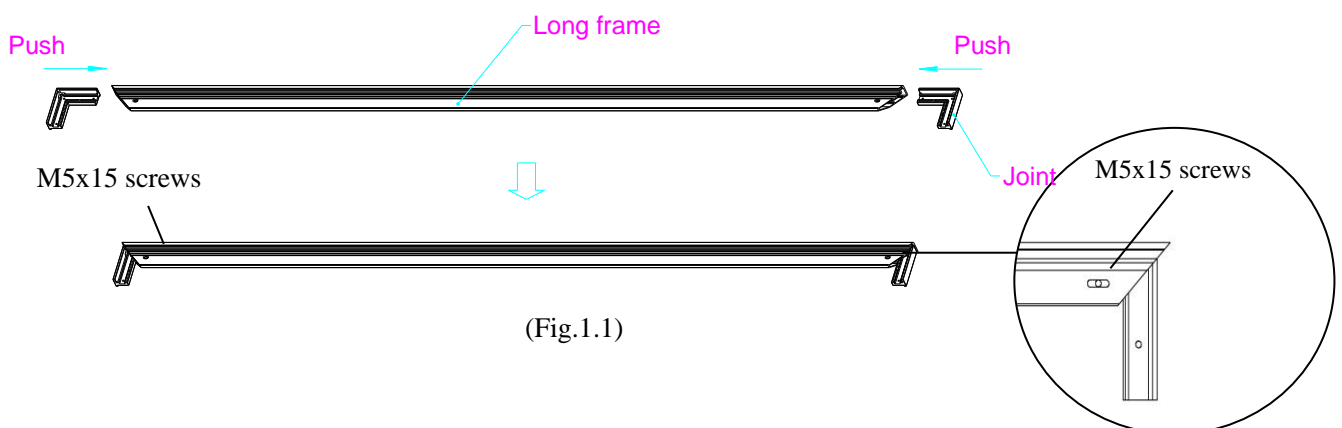

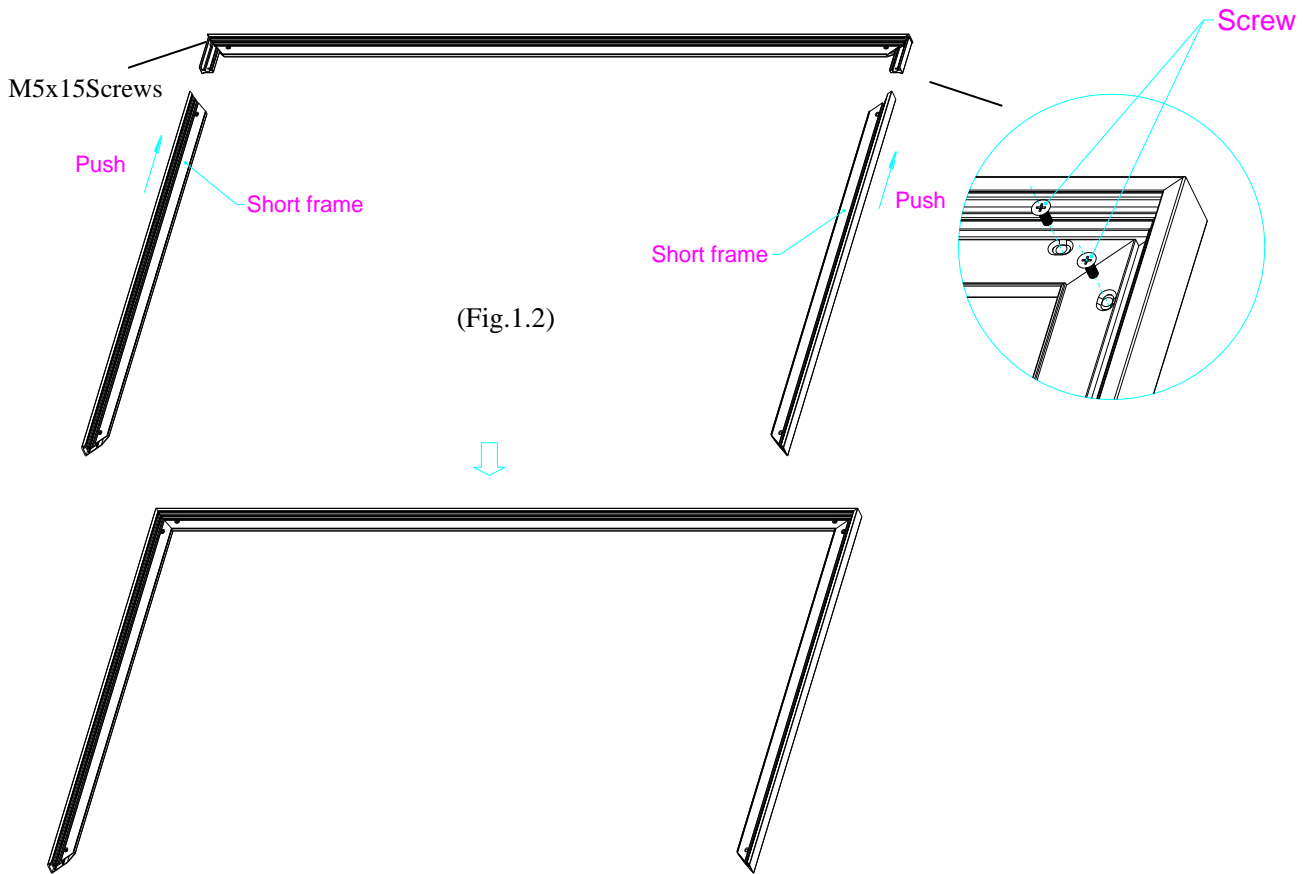

4. Join all four frame parts together following the steps shown below. (Fig.2)

Note: When assembled, please push simultaneously the two ends of the long frames.

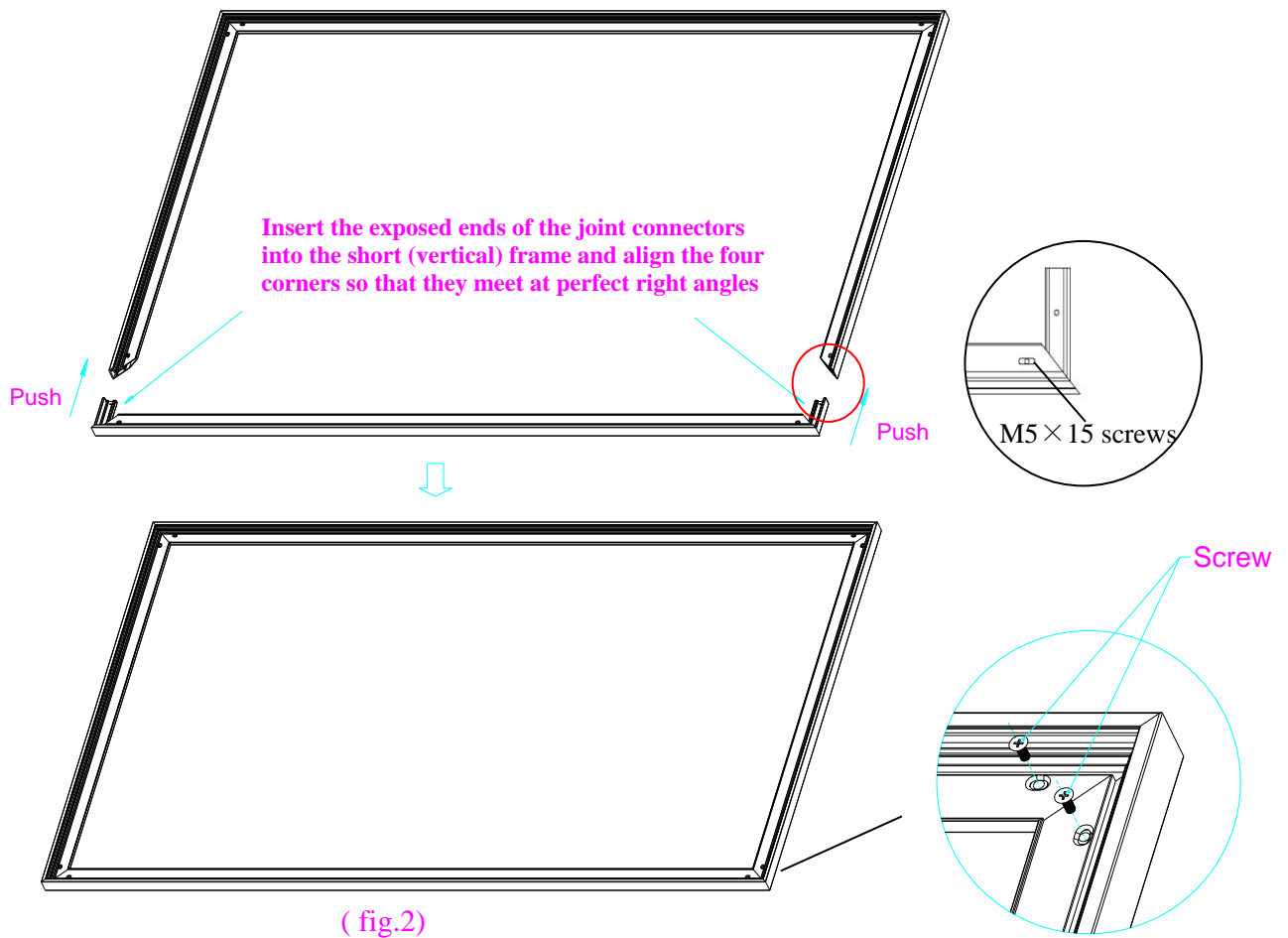

Attaching the screen material to the frame

1. Make sure the screen material and frame are both lying face down on a clean, dry, and non-abrasive surface.
2. Carefully unroll the material inside the frame. (Fig.3)

Please note the material will be noticeably smaller than the frame, as the material must be stretched to create a sufficient amount of tension for perfect material flatness.

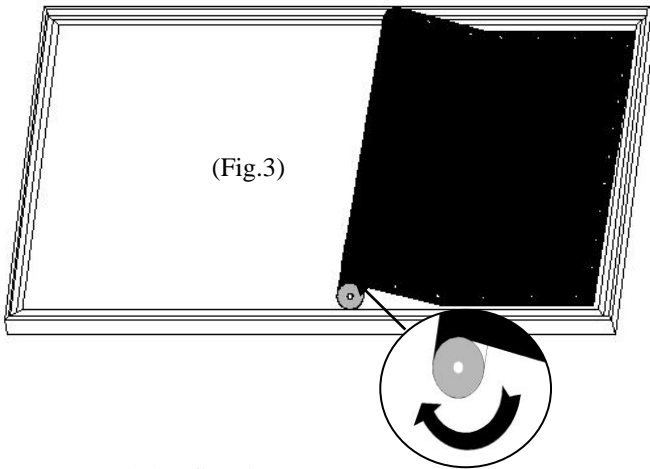

Notes:

- Make note of the label to help distinguish the back and front side.
- Unroll the screen material face down
- Keep the screen material as close as possible to the frame and do not allow it to scratch against any part of the frame.

3. Attach the fix plates.

- (1) Stretch the material to the corner and insert the screen material's edge in the groove of the frame. While one hand holds the material in place the other hand snaps in the push plate (Fig.4-Fig.5).

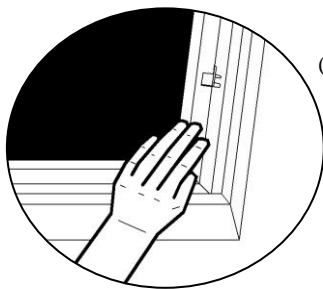

(Fig. 4)

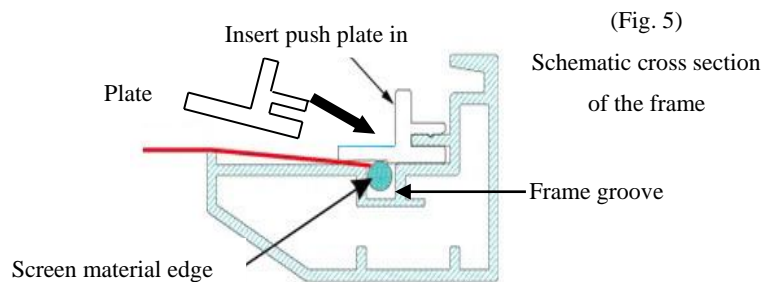

(Fig. 5)

Schematic cross section of the frame

- (2) Begin by securing the four corners in the following sequence A→B→C→D (Fig.6).

- (3) Insert the fix the plates as shown on Fig. 5. Fix plate ① is about 10cm away from the frame's corner. Fix plate ② is about 5cm away. (Fig.7)

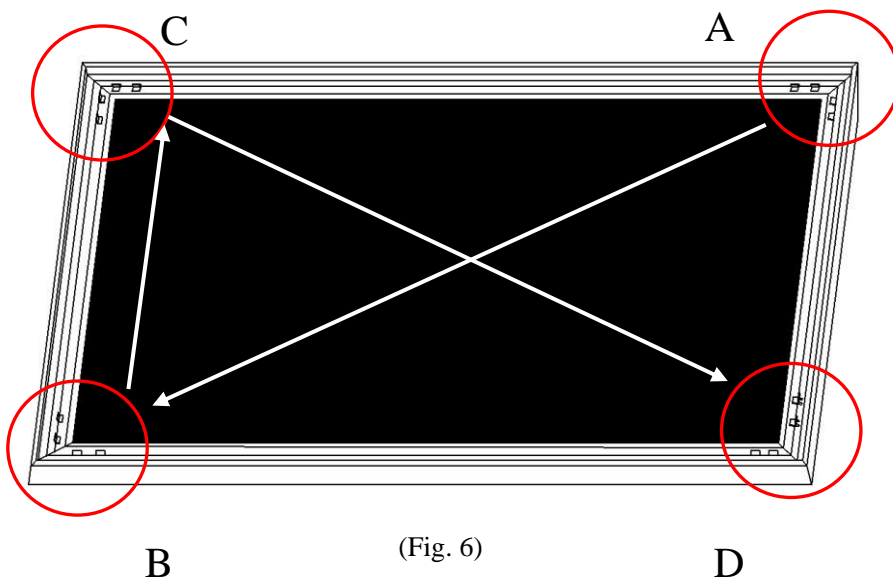

(Fig. 6)

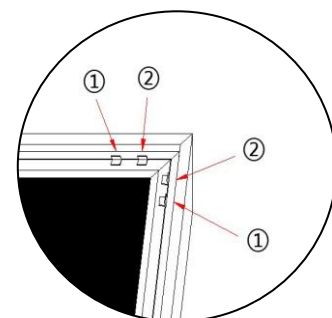

(Fig. 7)

Tip for attaching the last corner (D):

1. Position yourself left of location ①.
2. Pull the material to the corner of the frame with your hand while your left hand snaps in the fix plate on location ①(the third red dot).
3. Then insert and snap in the fix plate on location②.
4. Next, move and position yourself on location ③, then pull the edge to the frame and fasten plates on locations③and④.
5. Finally, fasten the last fix plate on location⑤. (Fig.8)

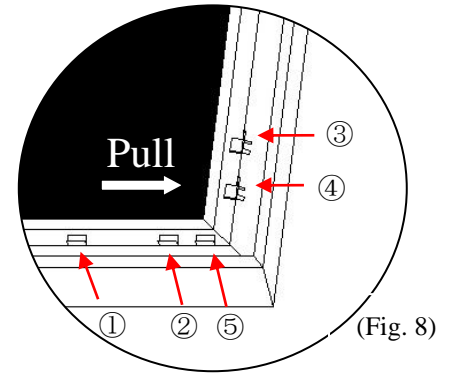

- (4) Place a fix plate in the center of each side in the following order E→F→G→H.(Fig.9)

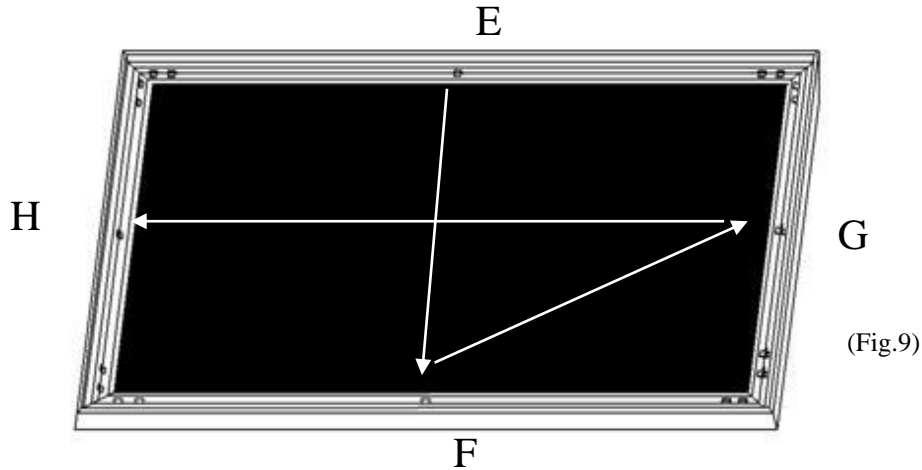

- (5) Next, fasten a fix plate on the center of each frame side in the following order I→J→K→L→M→N→O→P as shown in Fig.10.

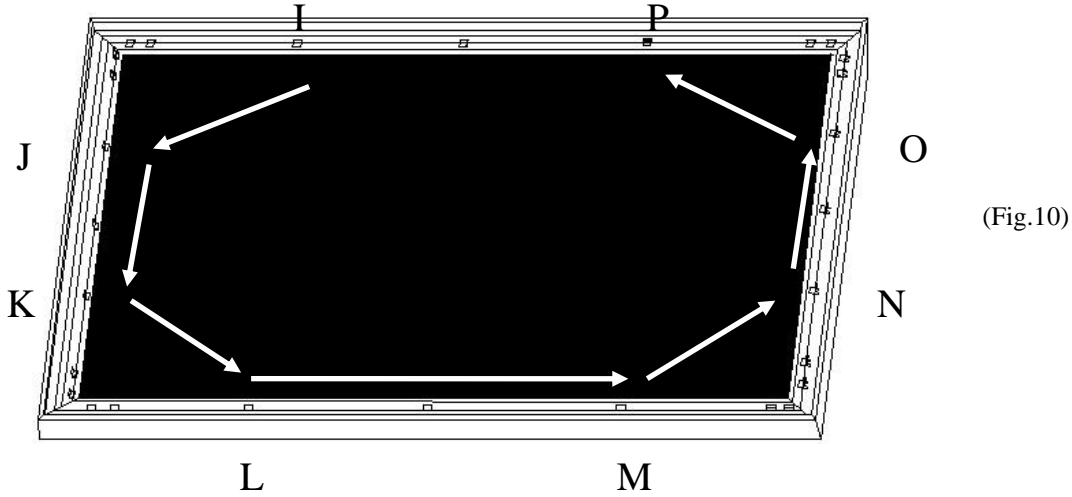

- (6) Fasten the remainder of the fix plates in the empty locations in the red markings to complete attaching the screen material. (Fig.11)

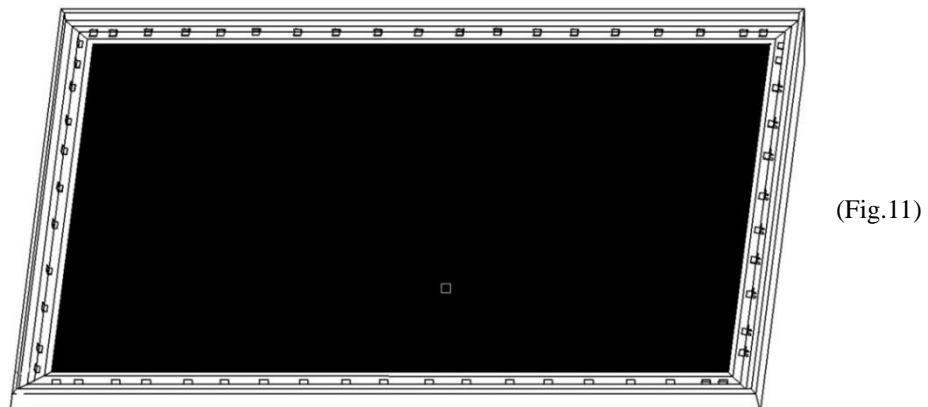

Center Support Bar

1. Insert the *support joiner (j)* into each end of the *center support bar (i)*.

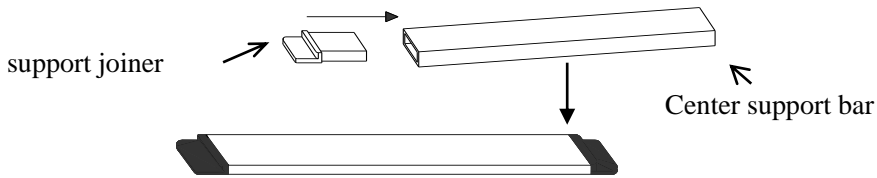

2. Insert the **Center Support Bar** into the upper top groove on the back of the frame (**not the one where the fix plate inserts**) with the bottom end near the approximate center point of the frame and rotate it in at an angle so that both ends of the bar are in alignment with the groove (see Fig. 16 and Fig. 17 below for details).

Diagonal models 135" and below use 1 x Center Support Bar

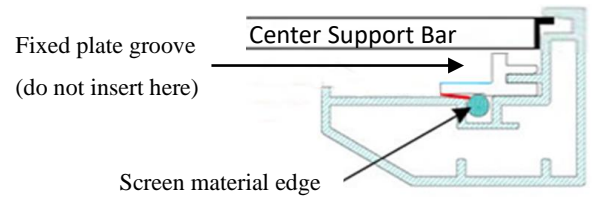
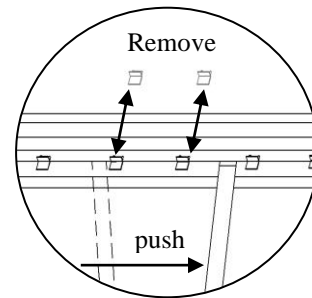
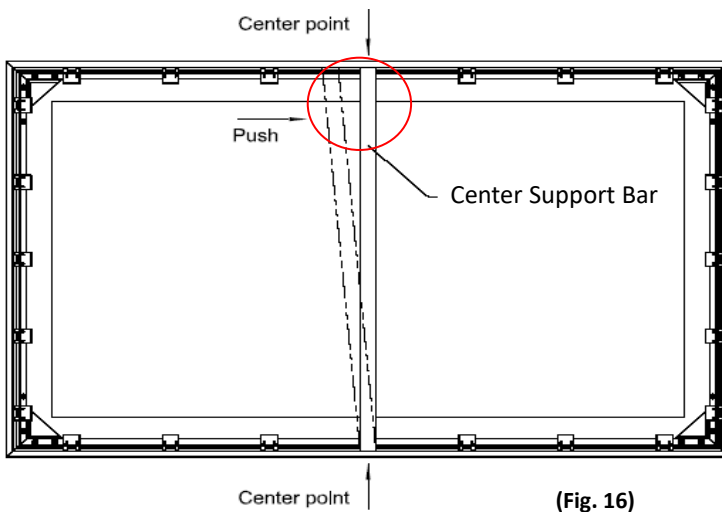

3. Slide the top end of the bar into the top center point of the frame to complete the center support bar installation. **This will provide added stability to your frame and added tension to the material.**

Diagonal models 135" and above use 2 x Center Support Bars

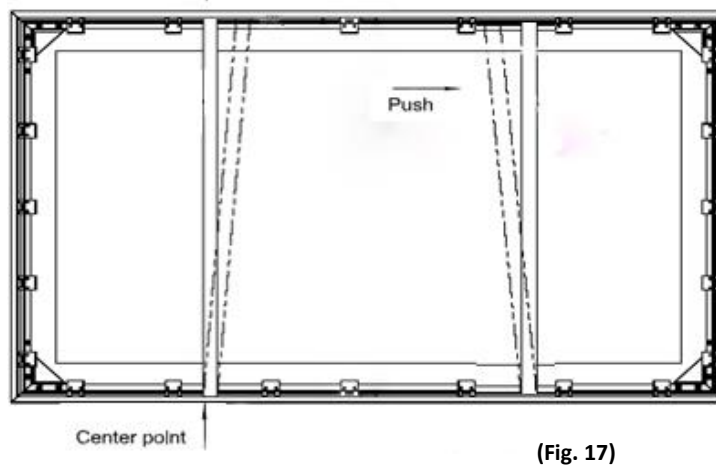

Installation

1. Locate your desired installation location with a stud finder (recommended) and mark the drill-hole area of where the screen is to be installed.
2. Drill a hole with the proper bit size according to the wood screws included.
3. Line up the wall brackets with the drilled holes on the installation location and screw them in using a Phillips screwdriver. **Note: Use 2 top wall brackets on diagonal sizes below 135", and use 3 top wall brackets on diagonal sizes 135".**
4. Position the fixed frame screen onto the top wall brackets as shown in (Fig. 18) and push down at the center of the bottom frame to secure the installation.
5. The design of the wall brackets allows the frame to slide over them through its sides. This is an important feature of the installation design as it allows your screen to be properly centered.
6. Using both hands finish the installation by pushing the lower portion of the fixed frame screen into the lower bracket as shown in Fig 19.

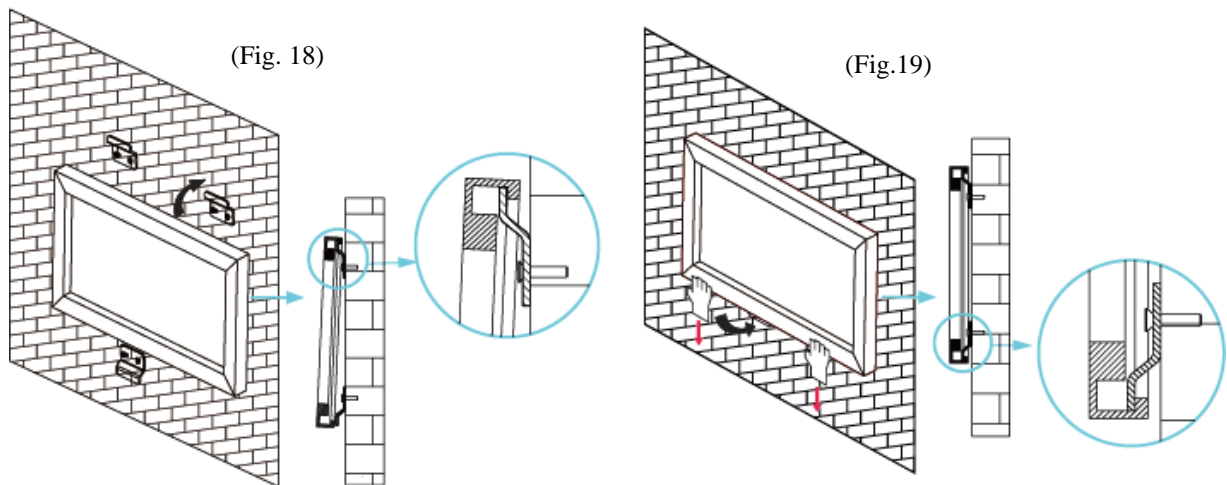

CAUTION

Please follow these instructions carefully to ensure proper maintenance and safety of your Fixed Frame Screen.

1. When hanging the screen up, please make sure that no other objects such as power switches, outlets, furniture, ladders, windows, etc. occupy the space designated for your Fixed-Frame screen.
2. Regardless if the screen is hung on or installed into the wall, make sure that the proper mounting anchors are used and that the weight is supported appropriately by a strong and structurally sound surface just as any large and heavy picture frame should.

(Please consult a home improvement specialist for the best advice on installation)

3. Frame parts are made of high quality velour-surfaced aluminum and should be handled with care.
4. When not in use, cover over the screen with a furniture sheet to protect it from dirt, grime, paint or any other impurities.
5. When cleaning, use a damp soft cloth with warm water to remove any marks on the frame or screen surface.
6. Never attempt to use any solutions, chemicals or abrasive cleaners on the screen surface.
7. In order to avoid damaging the screen, avoid touching it directly with your fingers, tools or any other sharp or abrasive objects.
8. Spare Parts should be placed out of reach of small children in accordance with household safety guidelines.

For a local Elite ProAV contact or Technical Support, please visit

www.eliteproav.com