



Presenter Pro CLR® 2 Series

Folding-frame model

Portable Indoor Ceiling Ambient Light Rejecting Screen

For tabletop/bottom mounted projectors

User's Guide – M type

Visit www.eliteproav.com for latest updated version.

Thank you for choosing the **Presenter Pro CLR® 2 Series®** projection screen! Please read through this user guide before utilizing the screen. Correct usage and maintenance will ensure a long product life.

Care & Use Instructions

- ◆ Elite ProAV highly recommends two people to assemble the screen.
- ◆ The **CLR® 2** is a Ceiling Ambient Light Rejecting screen material. It is a delicate optical/lenticular material and should not be folded, bent or creased. Always maintain screen material flat and taut during setup and disassembly.

**Elite ProAV is not responsible for damages due to negligence resulting from misuse or mishandling of the product and will void your warranty.*

Dust, dirt and debris on the projection screen surface will affect the quality and performance of the projection image. Follow the instructions below to properly maintain the screen.

- 1) Clean the dust on the screen surface with a soft brush or microfiber cloth.
- 3) Gently wipe the screen with a lightly moistened white lint free cloth with water.
- 4) Avoid putting pressure on the screen material when wiping the screen. If dust or other debris is on the surface, we recommend using an air sprayer to blow them away.

After using the screen, disassemble it and store it in the carrying bag provided.

**Make sure to keep the material protection film and tube for when disassembling the screen.*

- ◆ To avoid damage and injury, the screen should only be operated by adults.

Notes: The following precautions should always be followed to avoid damaging the material, which is not covered under warranty.







- Don't touch the screen material to avoid leaving fingerprints.
- Use gloves when handling the material.
- Don't allow the material to bend, fold or bunch as it will create permanent creases.
- Don't point to the screen material with a fingertip or other sharp objects to prevent damage to the material.
- Don't use acetone, benzene, alcohol and any other organic solvents to clean the screen material. Using such chemicals will permanently damage the screen

Product Description

Design: The aluminum frame is designed to be light weight and easy to handle when setting up or taking it down. Portability makes the screen easy to carry.

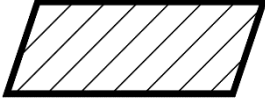
Screen Fabric: The screen fabric is attached to the rectangular frame and held in place by Velcro which ensures an evenly stretched and flat surface. The **CLR® 2** (front projection) screen material is delicate and should be carefully rolled to avoid any damage to the surface.

Hardware and Parts List

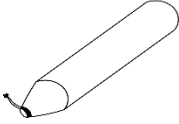
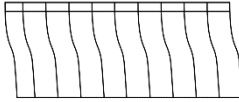
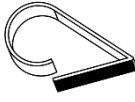
<p>A. Folding frame</p> 	<p>B. Left /Right folding legs</p> 	<p>C. Projection screen material</p> 	<p>D. Protective foam sheet and pair of gloves</p> 	
<p>E. Carrying Bag</p> 	<p>F. Knob screw</p> 	<p>G. Screen material bag</p> 	<p>H. Skirt</p> 	<p>I. Skirt hook</p> 

Item	Parts List	103"	123"
A.	Folding frame	1	1
B.	Left and right folding legs	2	2
C.	Projection screen material	1	1
D.	Protective foam sheet and pair of gloves	1	1
E.	Carrying Bag	1	1
F.	Knob screw	8	8
G.	Screen material bag	1	1
H.	Skirt	1	1
I.	Skirt hook	5	7

Note: The parts list above is subject to change without notice.

Frame Assembly and Screen Material Attachment

1. Take the folding frame (A) out of the carrying bag (E) and place it on a flat surface. Unfold the longer sections first. (Fig. 1-3).

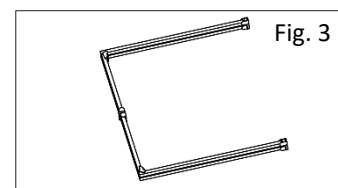
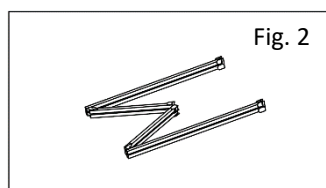
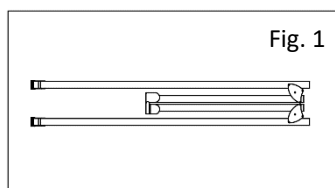

2. Unfold the frame until the latch on the hinge "clicks" into place. Repeat the procedure for the shorter sections. (Fig. 4-5)

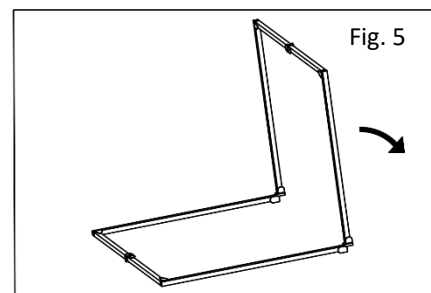
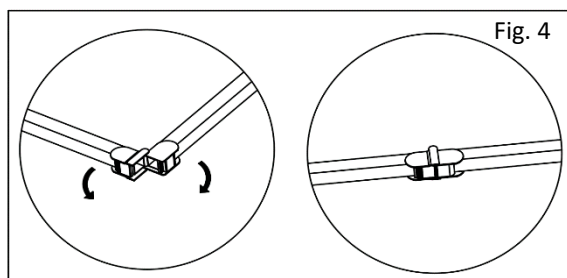

3. Make sure all 4 corners of the frame are at a 90° angle and the hinged support bar is straight and not bending (Fig. 6-7). After unfolding the frame, make sure to lay it out with the Velcro facing up (Fig. 8).

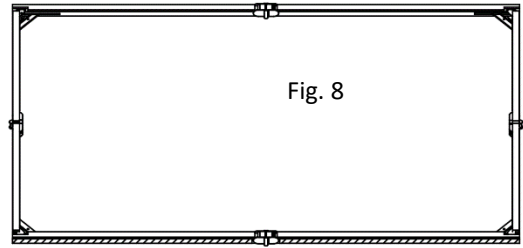
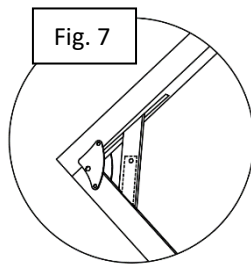
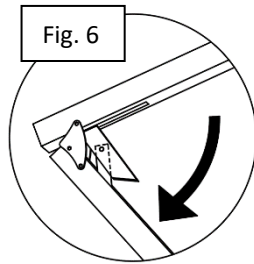

CAUTION!

THE PROJECTION FABRIC IS A DELICATE OPTICAL/LENTICULAR SCREEN MATERIAL AND SHOULD NOT BE FOLDED, BENT, OR CREASED. ALWAYS MAINTAIN SCREEN MATERIAL FLAT AND TAUT DURING SETUP AND DISASSEMBLY.

IMPORTANT: TWO PEOPLE ARE REQUIRED TO SETUP AND INSTALL THE MATERIAL TO AVOID PERMANENT DAMAGE. ANY DAMAGES TO THE SCREEN MATERIAL WILL VOID YOUR WARRANTY.

4. Carefully take out the screen material tube from the carrying bag and ONLY handle it HORIZONTALLY with two hands to avoid dropping it (Fig. 9).

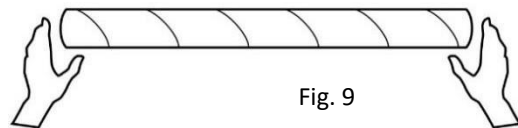

5. Once the screen material tube is on a flat surface horizontally, remove both end caps and gently pull out the screen material out of the tube. **DO NOT TRY TO SQUEEZE THE MATERIAL OUT OF THE TUBE TO AVOID IRREVERSIBLE PERMANENT BENDING/CREASING.**

6. Carefully unroll the screen material on a clean surface from the roller to the other side. (Fig. 10) place it on top of the frame with the projection side facing up (Fig. 11).

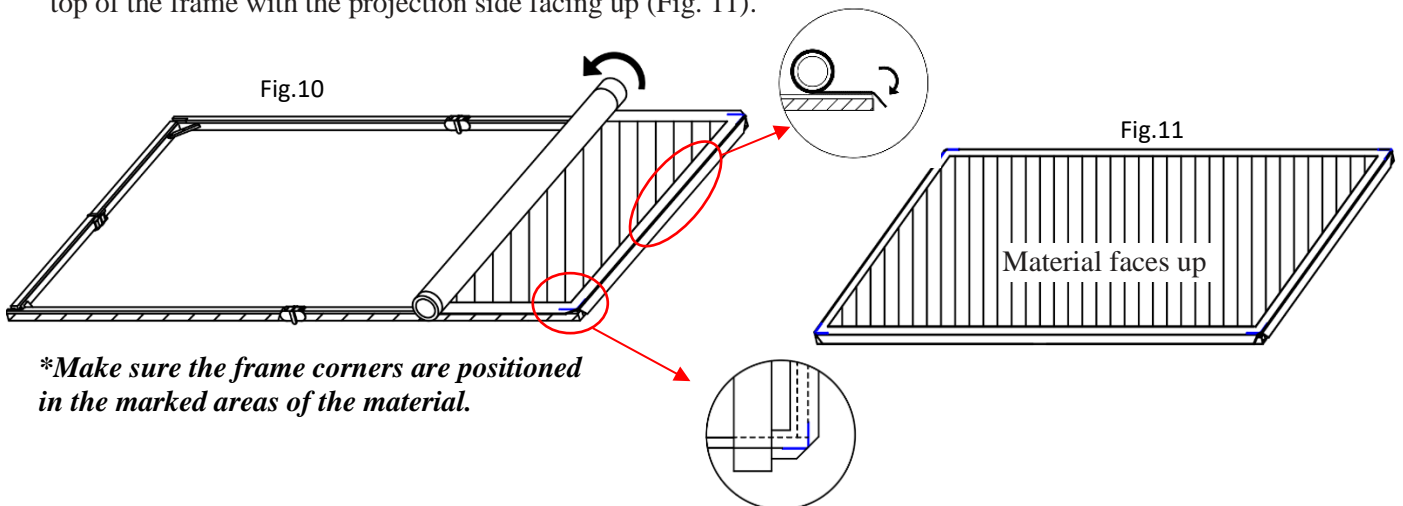

**Make sure the frame corners are positioned in the marked areas of the material.*

7. Begin attaching the material from the corners in the following sequence (Fig. 12).

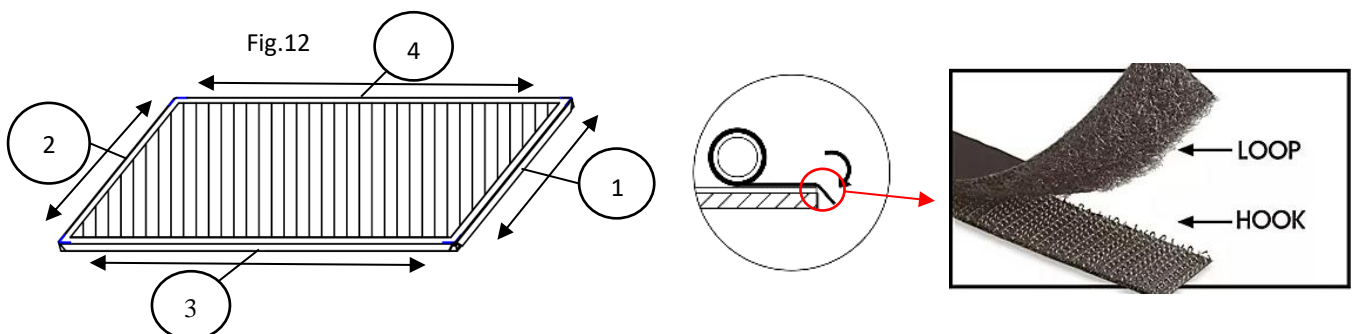

8. Lay the protective foam sheet on a clean flat surface and flip the screen over on the backside and place it on top of the sheet (Fig. 13).

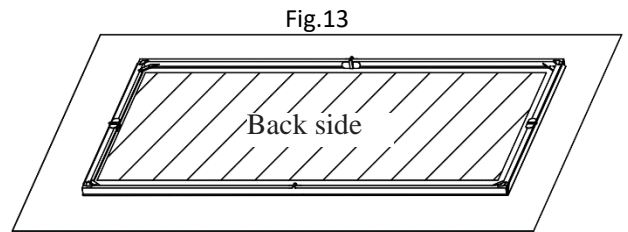

LEGS ATTACHMENT

9. Carefully take the *folding legs* (B) out of the *carrying bag* (E) and place them on a flat surface.

Warning: The additional support sections, located at the middle section of the legs, may unfold on its own. Please be sure to use caution while removing/placing the legs from/to the bag.

10. Unfold the legs and position them on the back of the frame as shown below.

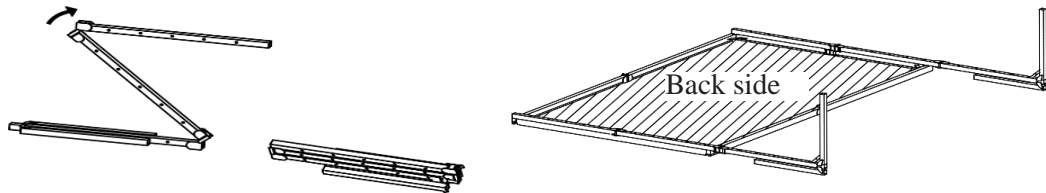

Height adjustable feature: The screen allows for the main frame to be set at various height intervals.

11. Lay the legs over on the back of the frame in the position desired.

Once you have aligned the leg's holes with the frame's holes, secure with the *knob screws* (F).

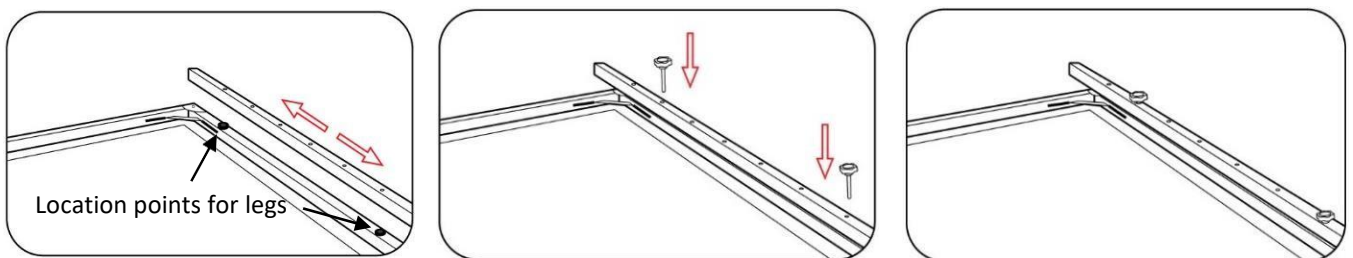

12. Next, lift the screen up while simultaneously opening the front frame legs. Two people are needed for this step.

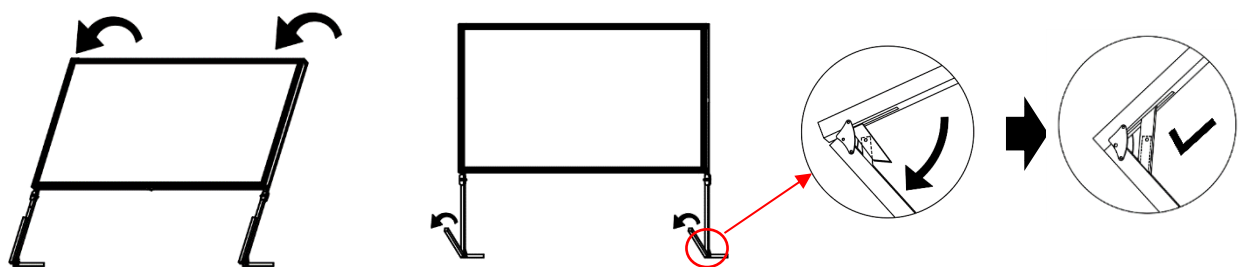

13. Full screen assembly is now complete.

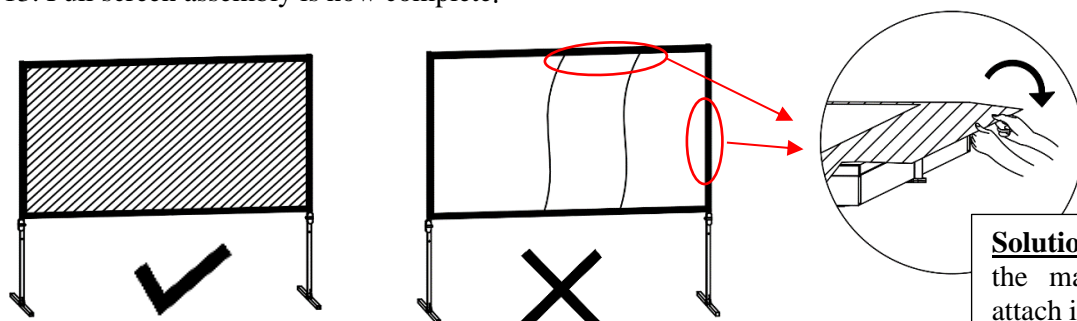

Solution: Pull the edges of the material outward and attach it again.

DRAPE/SKIRT INSTALLATION

14. Fasten the skirt(*H*) on the skirt hook (*I*), then attach along the bottom of the frame as shown below.

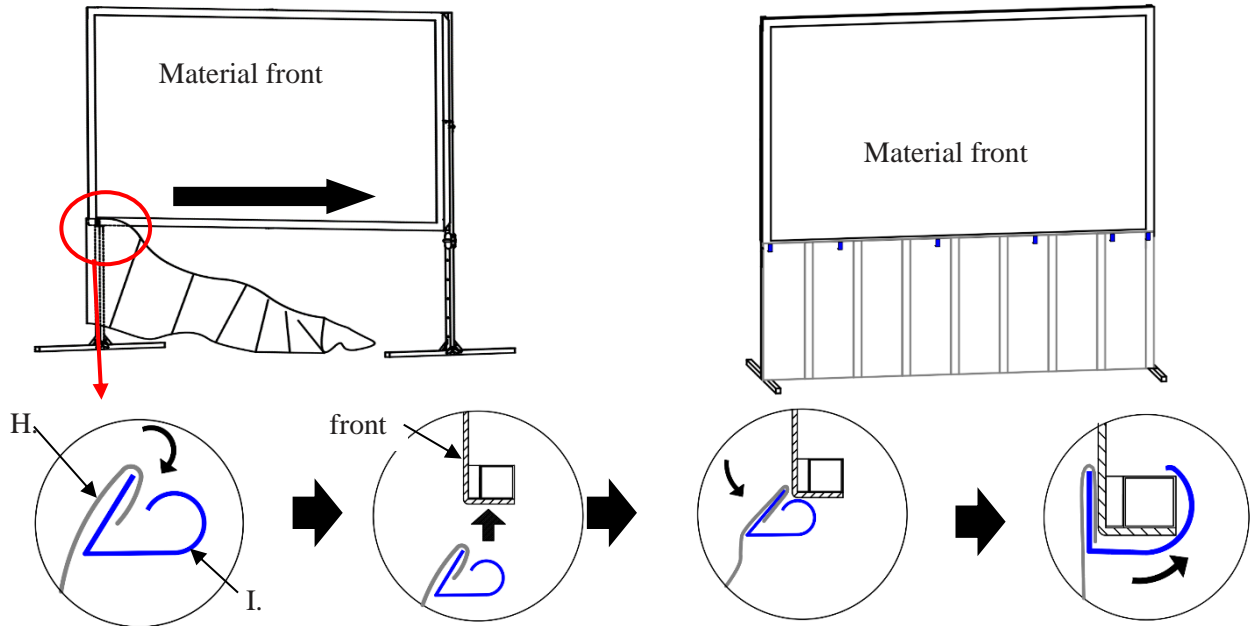

Notice to Installer:

PROPER PROJECTOR PLACEMENT

The CLR® 2 is exclusively for tabletop/bottom mounted ultra and short throw projectors. See illustrations for limits and criteria.

1) **Tabletop mounted Ultra-short throw projector illustration.**

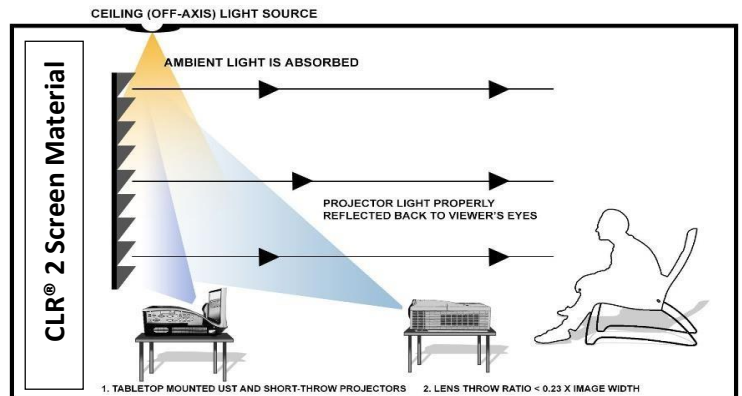

IMPROPER PROJECTOR PLACEMENT

Overhead placement or a standard projector will make the image very dark, on account of the screen's absorbent layer deflecting light that is not aligned with its reflective angle.

1) **Ceiling Mounted Ultra- Short Throw Projector Illustration.**

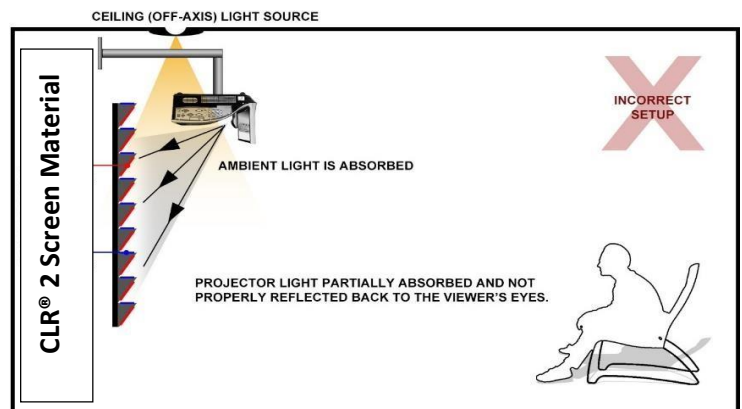

2) **Ceiling Mounted Short and Standard- Throw Projector Illustration.**

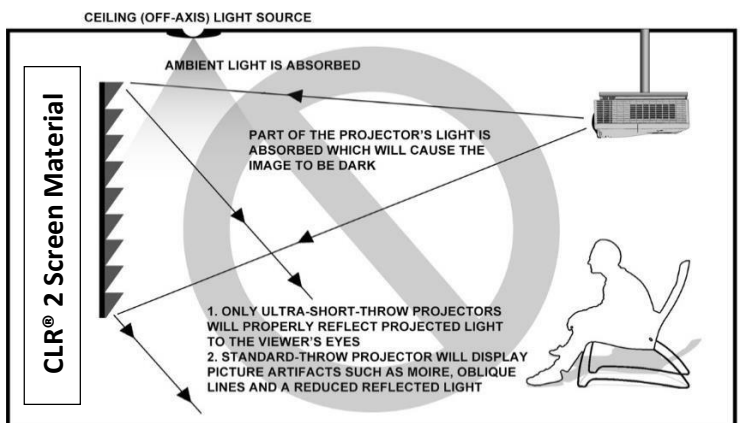

Screen Disassembly

TWO PEOPLE REQUIRED

1. Lay the protective foam sheet on a clean surface and unhinge the front of each leg, then SLOWLY lower the screen down on the foam sheet.

NOTE: Front side of the material should be facing down on the protective foam sheet.

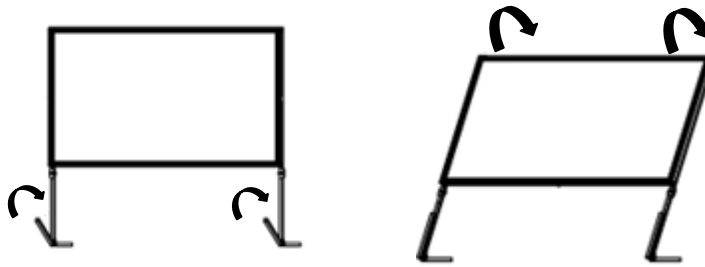

2. Once the screen is laid out on the protective foam sheet, unscrew all the knob screws on each side of the frame to remove the legs.

4. Next, turn over the screen so the front is facing up.

3. Unattach the material edges from the velcro on all sides. Then place the tube on top of the screen material and attach the edge of to the Velcro on the tube.

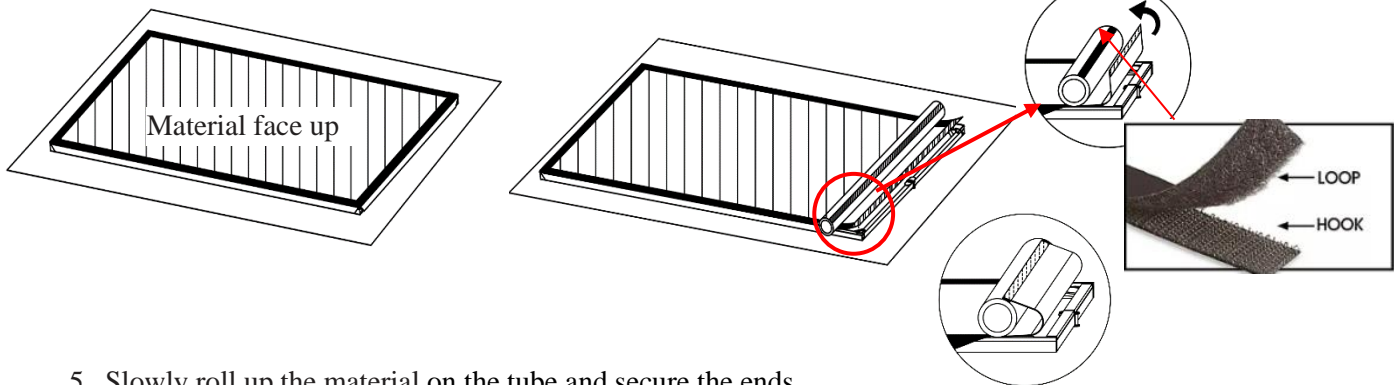

5. Slowly roll up the material on the tube and secure the ends.

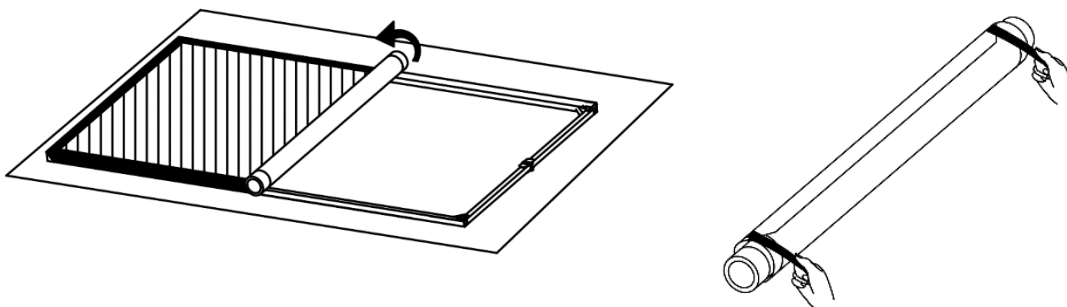

6. Then insert the material rolled on the tube into the bag.

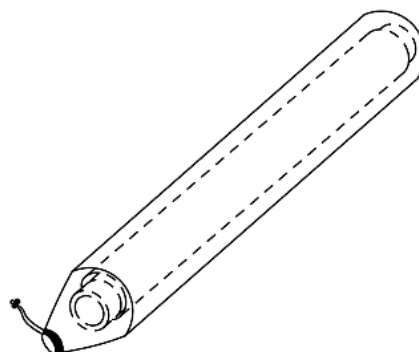

7. Once the material has been completely rolled, insert the rolled material with the outer tube lying horizontally. DO NOT force it in as that will crush the ends and damage the material.

If the material does not fit in snugly, re-roll the material.

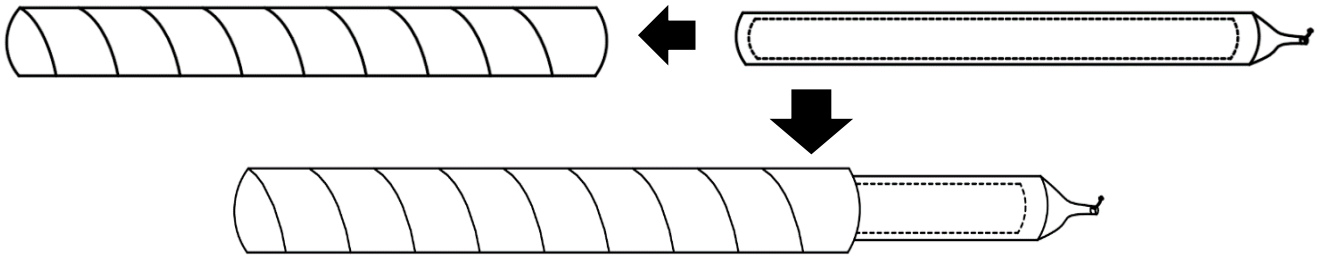

8. After the material is completely inside the outer tube, put the end caps back on to secure the material.

9. Unlatch the hinged support bars in each corner of the *folding frame (A)*.

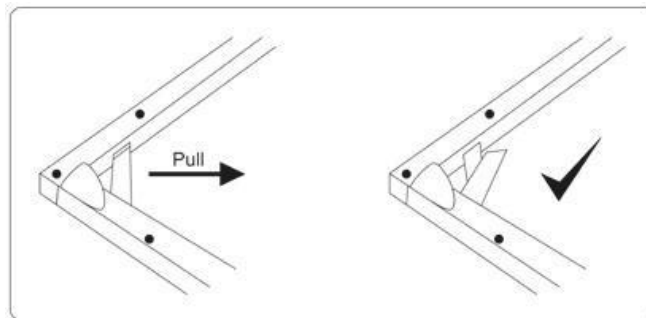

10. Press the locking buttons, near the folding joints, and slowly gather the sides of the folding frame.

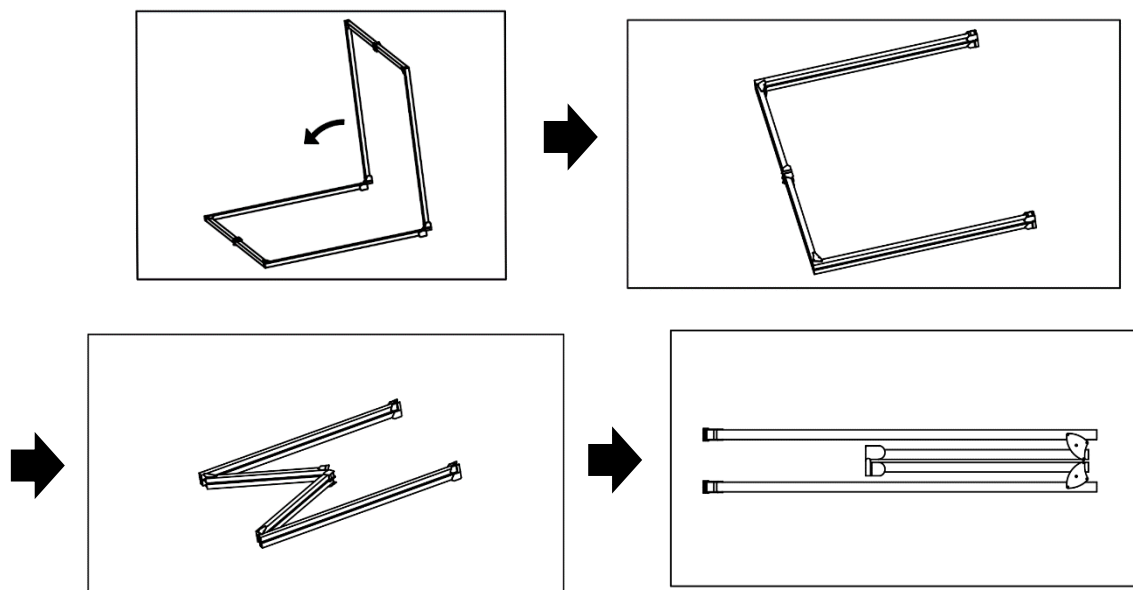

11. Again, press in the locking buttons. Then, pick up one end of the folding frame, and walk it to the other end, folding the longer sections in half.

12. Carefully place the screen and components in the provided *carrying bag (E)*.

For a local Elite Screens contact or Technical Support, please visit

www.eliteproav.com