



Pro Frame Thin Series

EDGE FREE® Matte White Fixed Frame Screen

USER'S GUIDE – E Type



Product Description:

The **Pro Frame Thin Series** is a fixed frame projection screen that uses Elite ProAV's EDGE FREE® technology. The EDGE FREE® design resembles a giant size flat panel TV display. The **Pro Frame Thin** includes a micro-thin aluminum bezel trim to further enhance the frame appearance. An LED kit is also included for mood lighting.

The screen material included is our *CineWhite®*, which is a matte white tensioned front projection material for environments with controlled lighting.

For optimum projection qualities and performance, please refer to the list below for proper maintenance and cleaning.

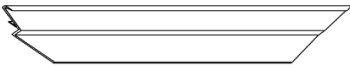
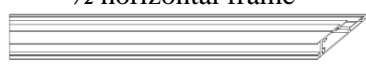
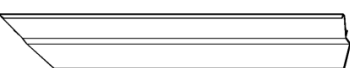
- Use a dry microfiber cloth to remove dust from the screen's surface.
- When cleaning, use a damp microfiber cloth with warm water to remove any marks.
- Never rub or apply pressure when cleaning the surface.
- Never attempt to use any solutions, chemicals or abrasive cleaners on the screen surface.
- In order to avoid damaging the screen, avoid touching it directly with your fingers, pens/pencils or any other sharp or abrasive objects.

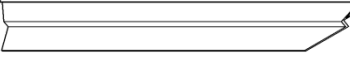
1. Frame and Edge Trim Parts List			
Qty item	2 pcs Main Frame Parts	Qty item	2 pcs Edge Trim Parts
Part A.	vertical frame 	Part D.	
Part B.	½ horizontal frame 	Part E.	
Part C.	½ horizontal frame 	Part F.	

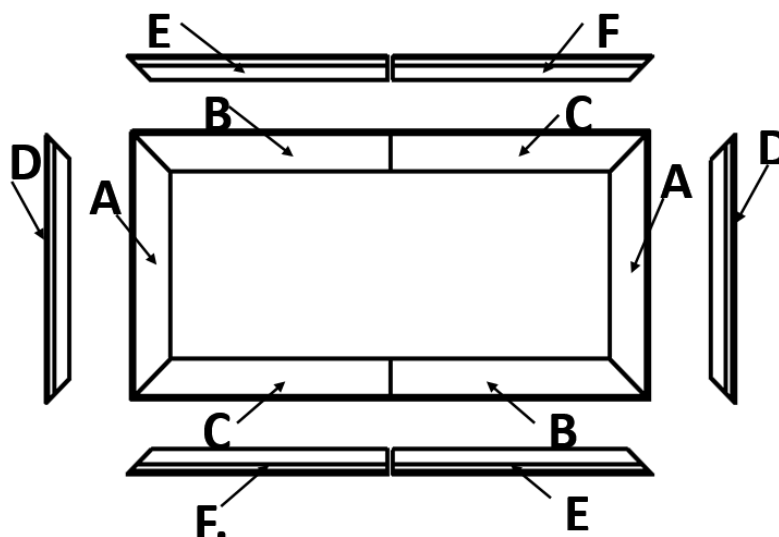

2. Hardware Parts List

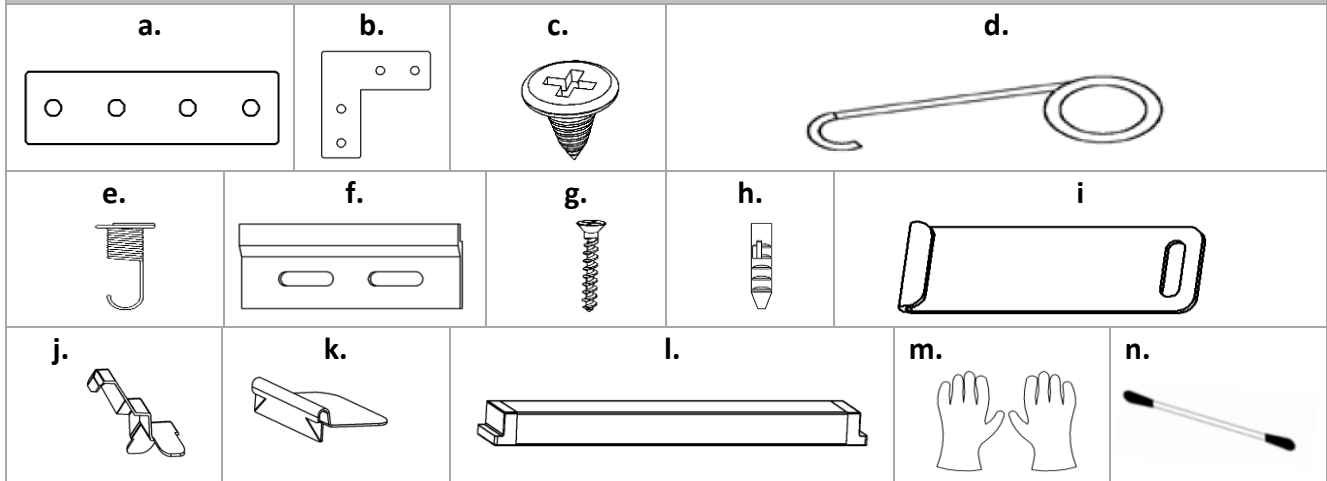

Item	Parts List	PFT 100H	PFT 110H	PFT 120H	PFT 135H	PFT 150H
a.	Center Joints (1)	4	4	4	4	4
b.	Elbow Joints (2)	8	8	8	8	8
c.	M4x6 Screws	60	60	60	60	60
d.	Spring Hook	2	2	2	2	2
e.	Spring	88	94	104	116	128
f.	Top wall brackets	2	2	2	2	2
g.	M5x50 Wall Screws	6	6	6	6	6
h.	Hollow Wall anchors	6	6	6	6	6
i.	Bottom wall brackets	2	2	2	2	2
j.	Angle cover	4	4	4	4	4
k.	LED light strip clip	8	8	8	8	8
l.	Center Support Bar	1	1	1	1	1
m.	White gloves	2	2	2	2	2
n.	Fiberglass rods	6	6	6	6	6

Frame Assembly

Step 1: Place the soft padded foam sheet on a clean area on the ground where the screen will be assembled.

Step 2: Position the pieces of the frame on the foam sheet in the arrangement shown below.

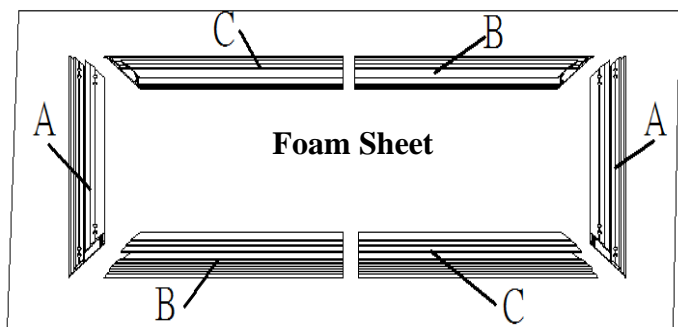
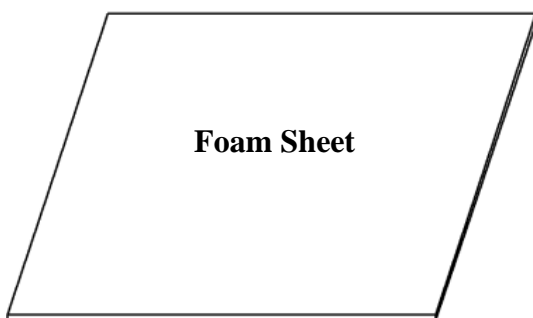

Step 3: Remove the foam on all frame ends before assembling the frame.

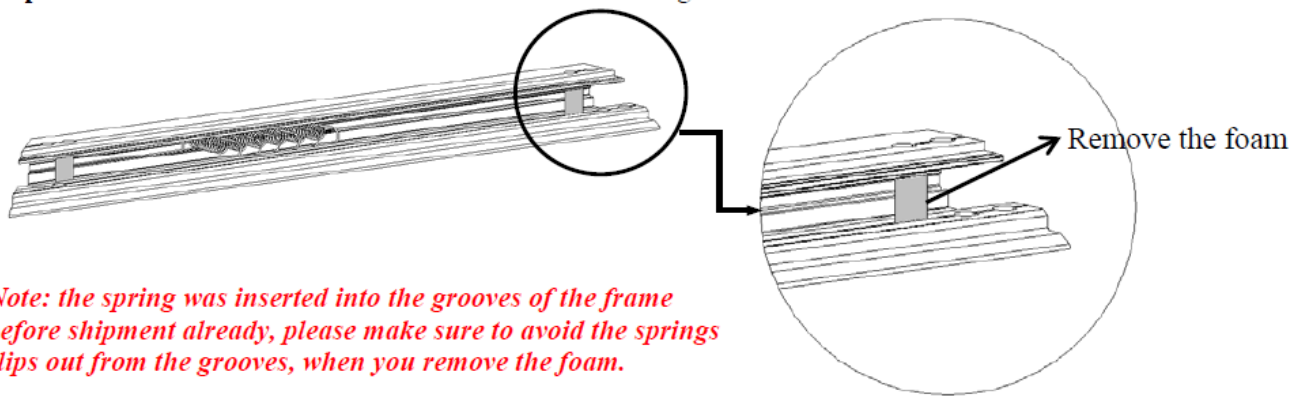

Step 4: Insert the *center joint (a)* connectors into *one-half of the horizontal frame (b/c)* and secure with the *M4x6 screws (c)*.

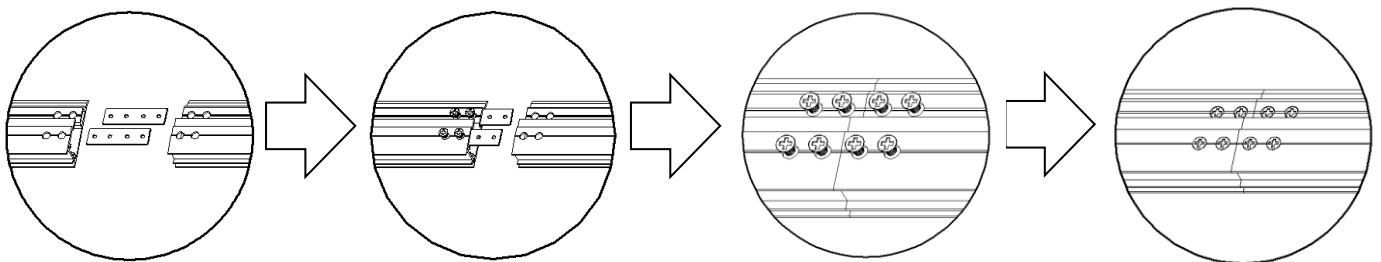

Step 5: Connect the *elbow joints (b)* to the top and bottom sections of the vertical frame. Once inserted, connect the vertical sections of the horizontal frame sections. Make sure all holes are in alignment and the frame pieces are flush (no gaps). They should form perfect right angles.

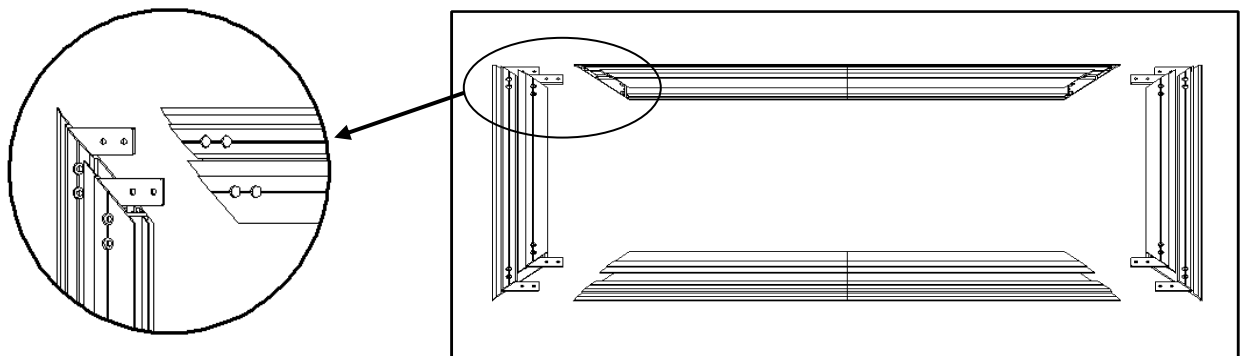

Step 6: Secure the elbow joints by fastening them with *M4x6 screws (c)*, 4 at each corner.

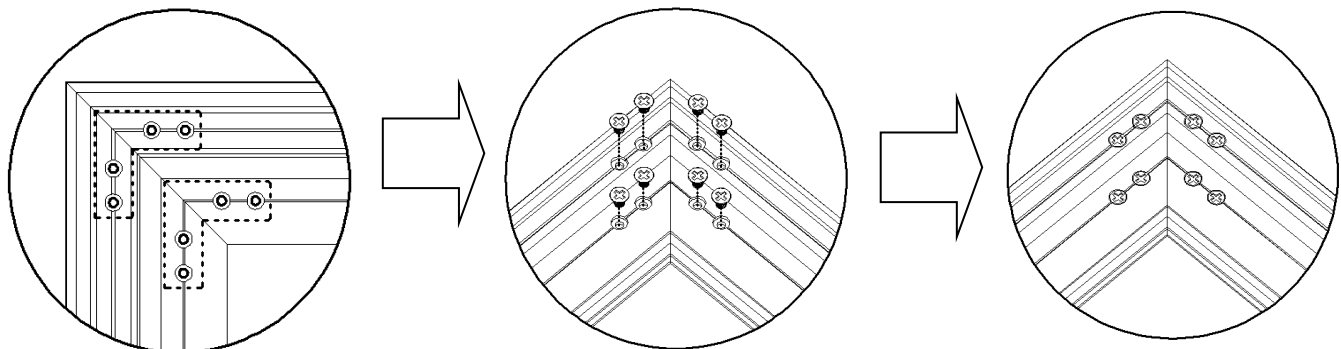

Screen Material

Step 7: Put on the *white gloves*(m) and carefully unroll the screen material on a clean surface from the roller to the other side as shown below. The back side of the screen material should be placed upwards.

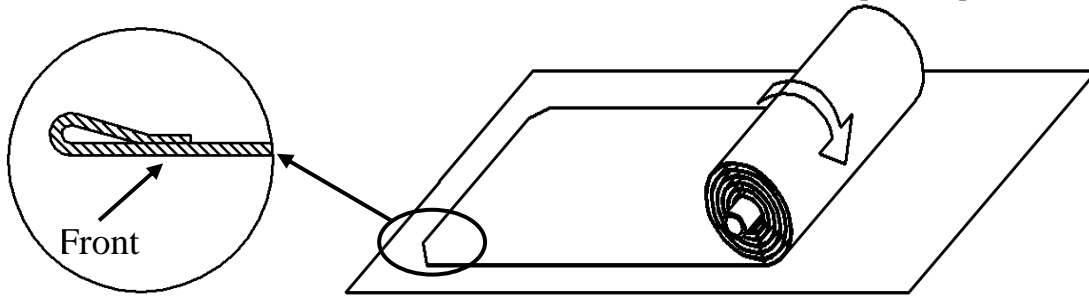

Step 8: Insert the *fiberglass rods* (n) through the openings. The longer rods are used on the vertical edges of the screen material, and the shorter rods are used on the horizontal edges, as shown below.

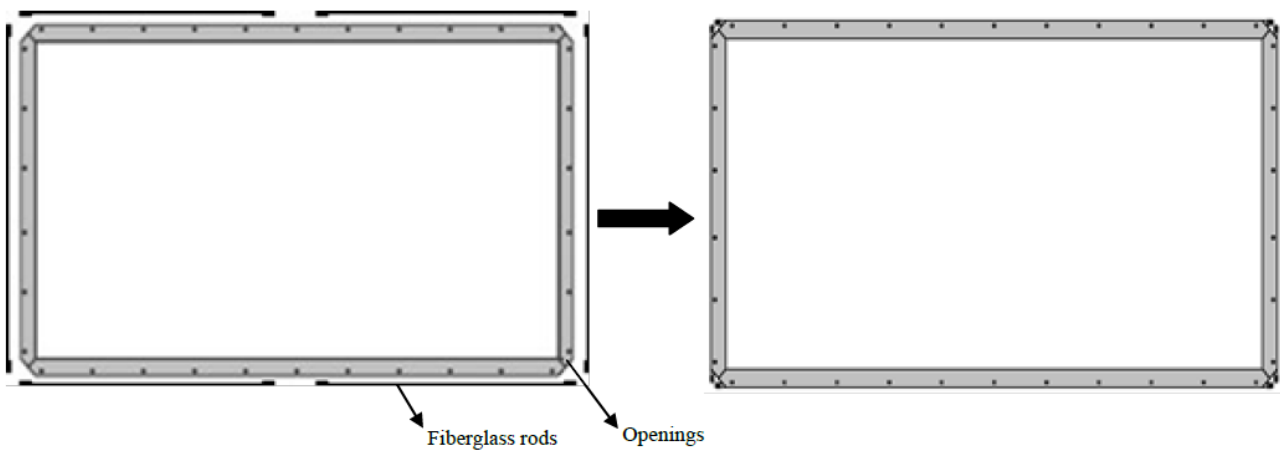

Step 9: Carefully and gently place the assembled frame on top of the screen material. Make sure to not allow the angle edge of the frame to come in direct contact with the screen material to avoid puncturing it.

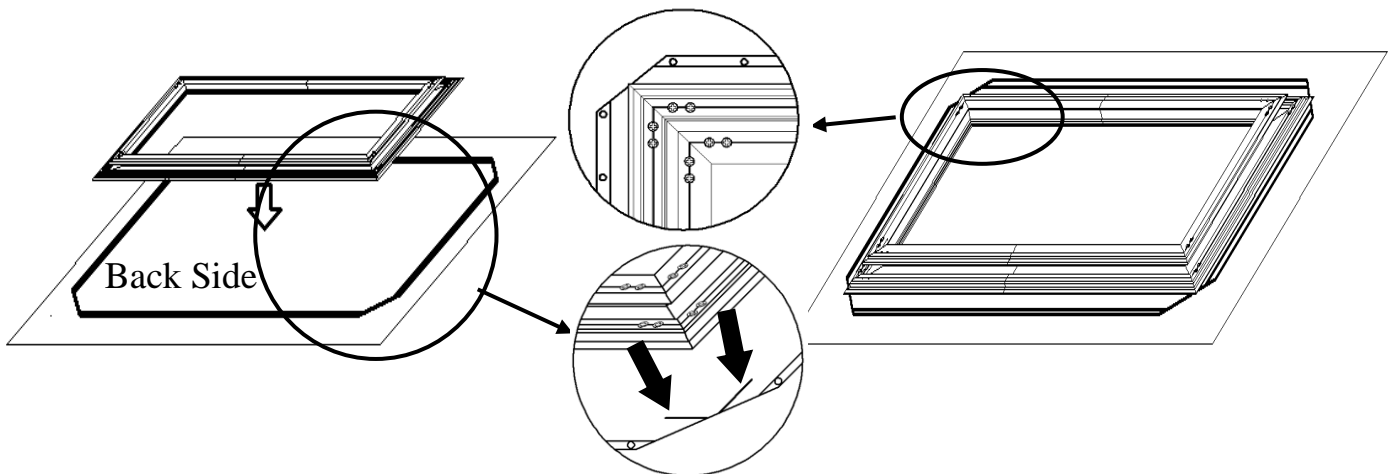

Step 10: With one end of the spring and secure inside the groove of the frame, use the *spring hook* (d) to attach the spring to the hole located on the screen material's outer edge in the following order.

Attach the four corners first (1). After those are secure, connect the vertical portions of the material, begin in the center and move towards the corners (2). Lastly, connect the horizontal sections of the material by connecting the center of the material and make your way towards the corners (3).

Note (after all springs have been attached):

Correct material installation –Corners of the screen material are properly wrapped around the corner edges of the frame and material is evenly tensioned and flat, creating a nicely taut surface.

Incorrect material installation –The corners of the screen material are not properly wrapped along the edge of the frame leaving the material with unbalanced tension and an uneven finish. To correct, detach springs from material at the corner(s) where material does not lie flat along the edge of the frame, reposition the material so that it lies flat and wraps along the edge of the frame, and reattach springs to the material.

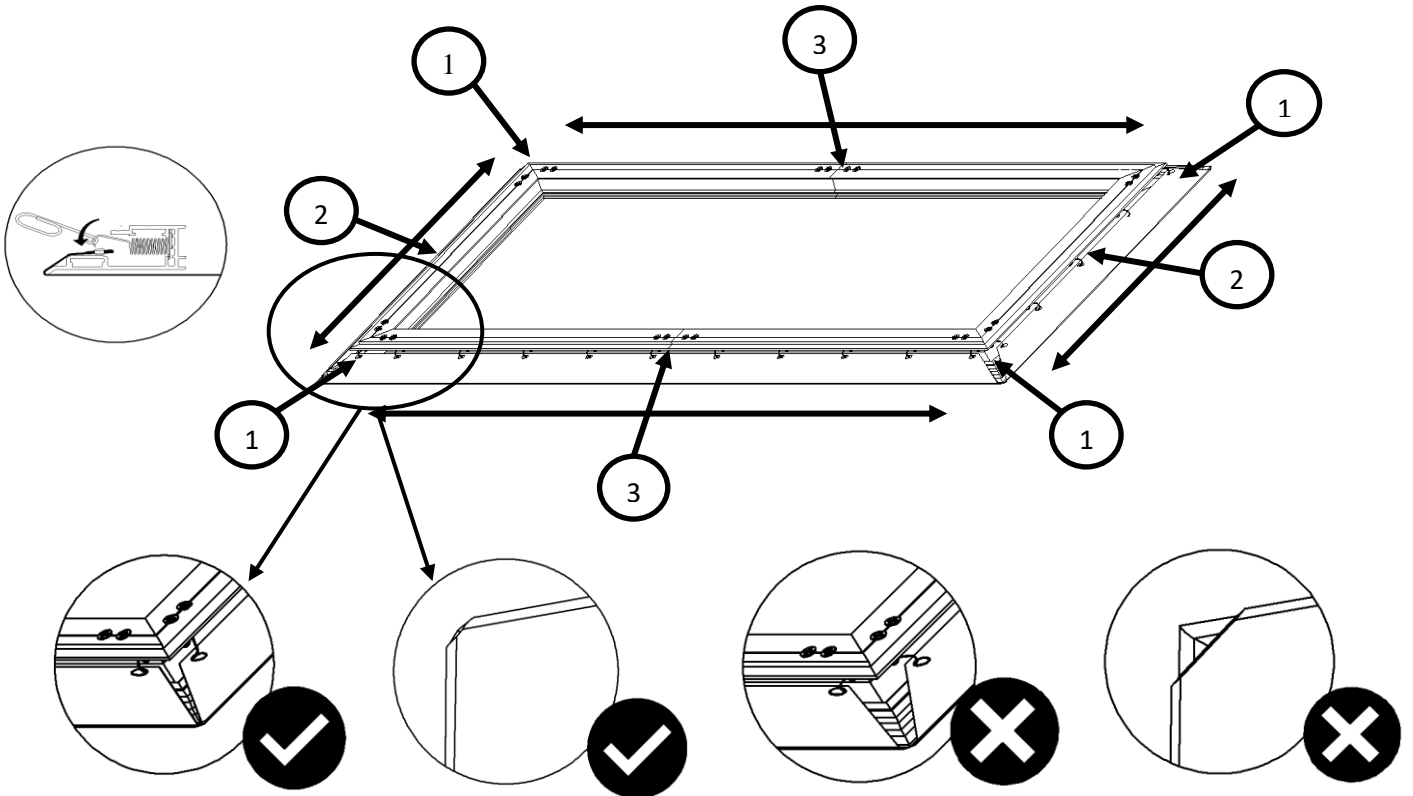

To avoid ripples forming in the material it is imperative that all of the corners are properly wrapped around the edges as illustrated in the check mark diagrams.

Center Support Bar

Step 11: Insert the *Center Support Bar (i)* into the upper top groove on the back of the frame with the bottom end near the approximate center point of the frame and rotate it in at an angle so that both ends of the bar are in alignment with the groove.

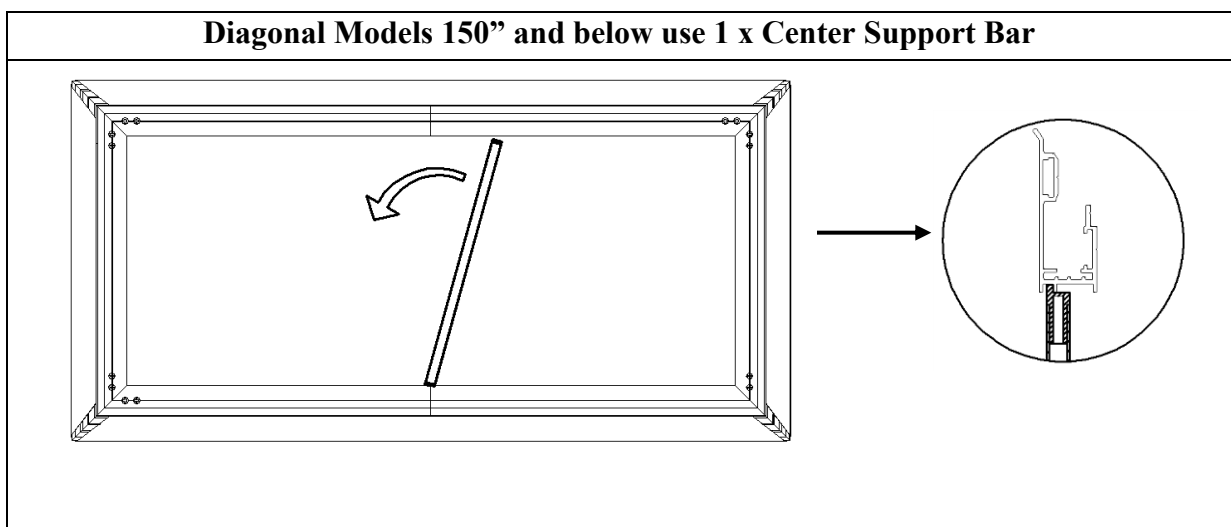

How to avoid getting ripples on the screen material's projection surface.

Solution: Pull and smooth out the material using your hand from the center to the corners, creating a nicely taut surface as shown below.

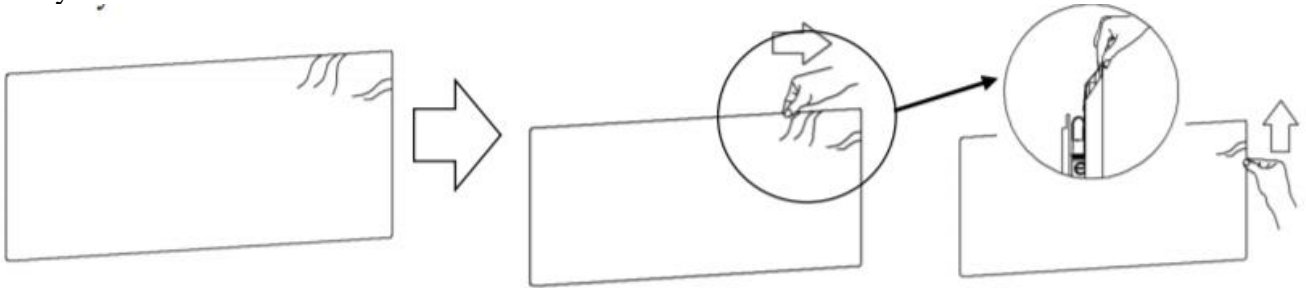

Attention: Do not proceed with the *Edge Trim* installation until making sure there are no ripples in the material.

Edge Trim Installation

Step 12: Place the *Edge Trim* over each end of the frame and secure with *M4x6 screws (c)*. Start with the center points first, then the rest of the corners as shown below.

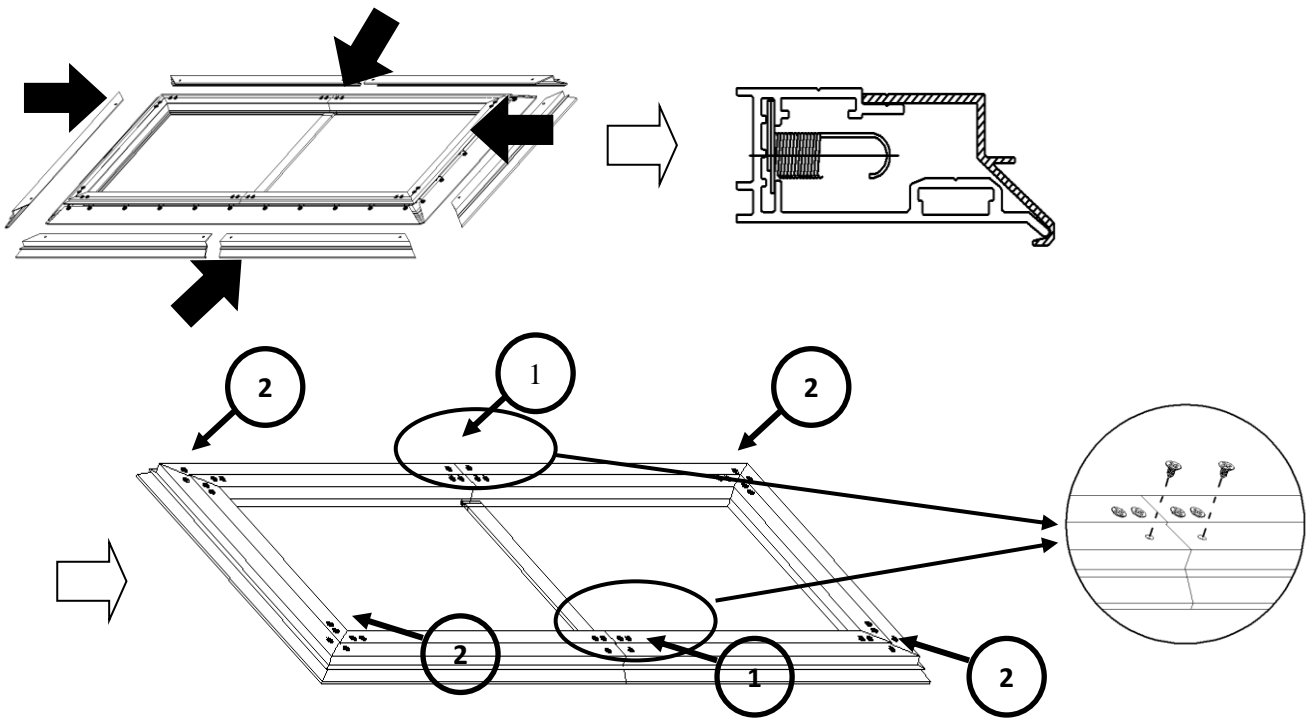

Step 13: Install the *angle cover (j)* on each corner of the frame and install the LED light strip to hold down the angle cover.

Then insert the *LED light clip (l)* to hold the LED light strip in place.

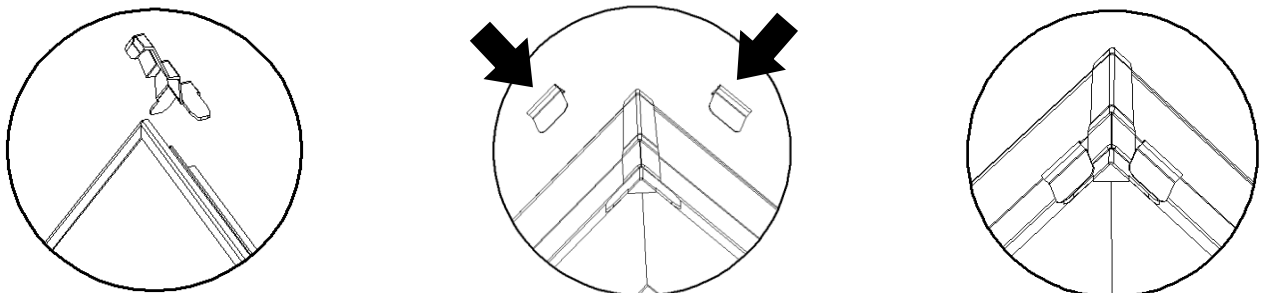

Wall Installation

Step 14: Measure the overall length and height of the frame and drill holes for the top brackets. Line up the wall brackets with the drilled holes on the installation location and screw them in using a Phillips screwdriver. If not installing into a structural wood stud, use a hollow wall anchor then screw in the M5x50 wood screws with a screwdriver. Make sure the brackets are leveled.

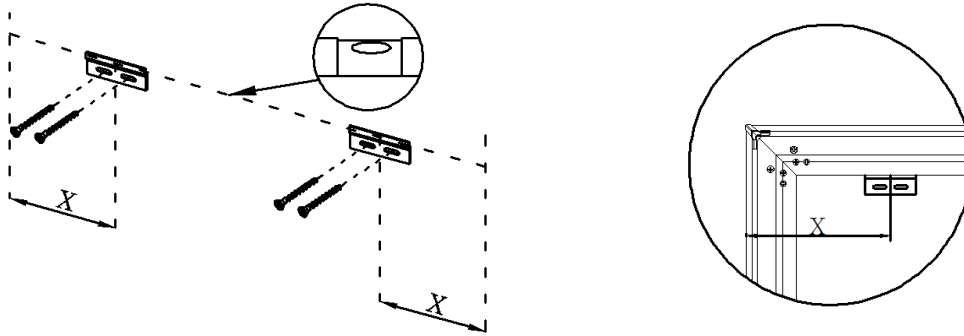

Step 15: Position the fixed frame screen onto the top wall brackets as shown below and push down at the center of the top of the frame to secure.

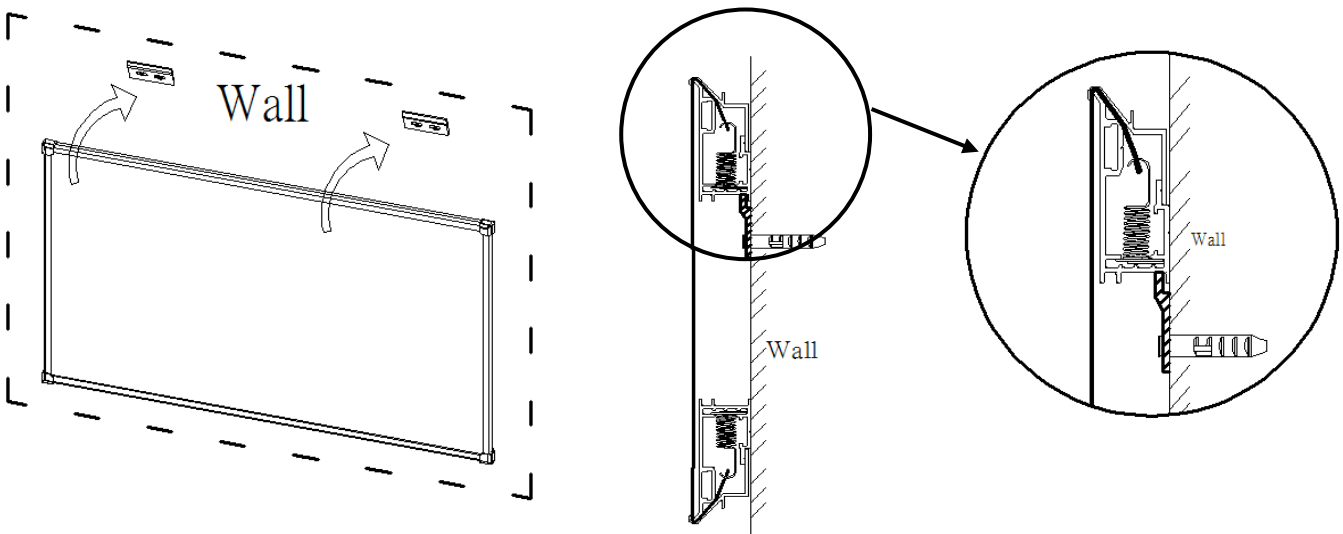

Step 16: With the frame slightly tilted outward; connect the bottom brackets onto the bottom groove of the frame. Then secure them by screwing onto the wall.

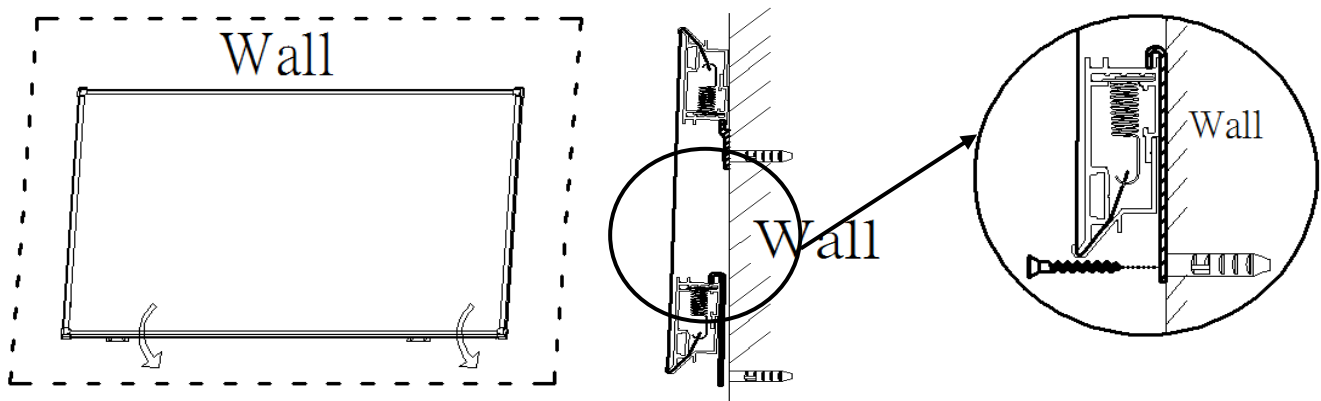

For Technical Support or an Elite ProAV contact in your area, visit

www.eliteproav.com